

When Applied Mathematics Collided with Algebra

Nalini Joshi



Supported by the Australian Research Council

A Reflection

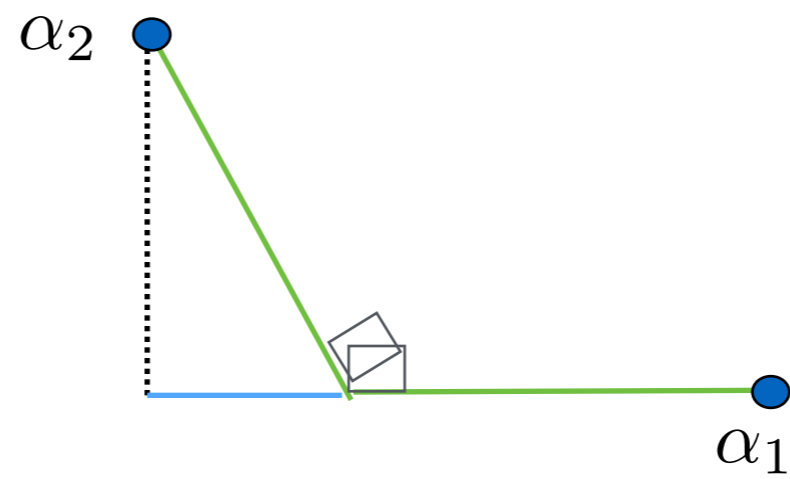

A Reflection

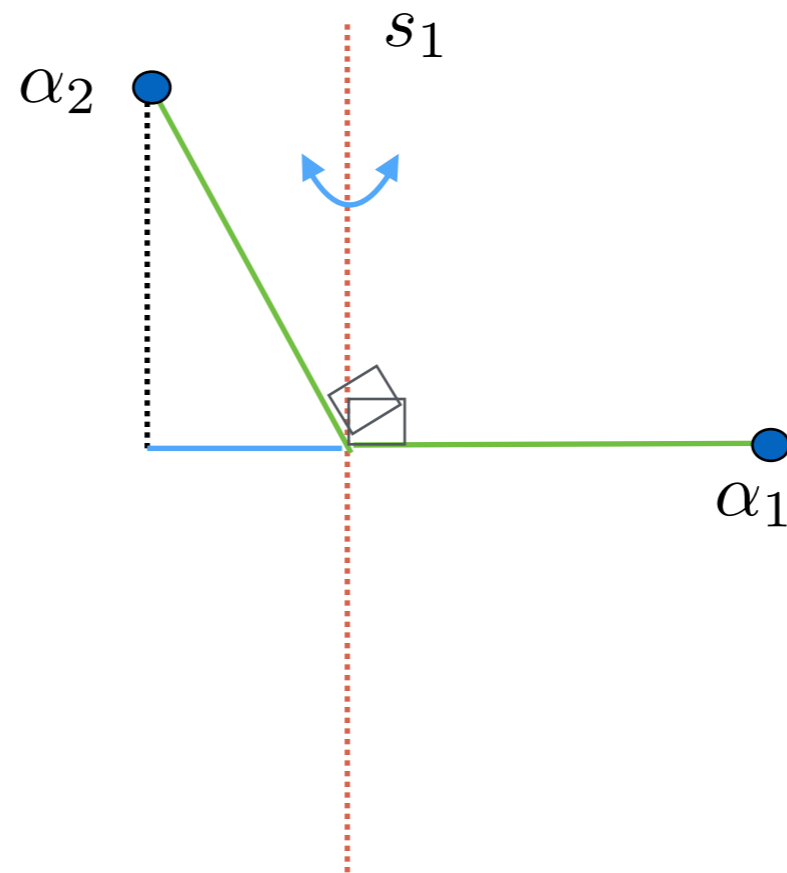

A Reflection

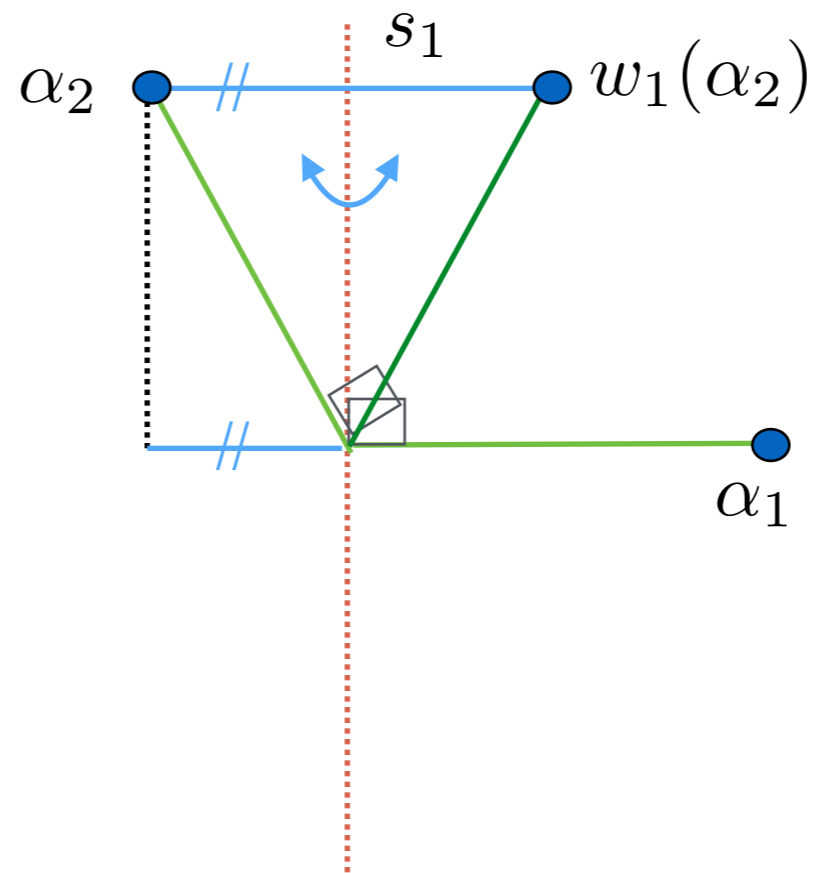

A Reflection

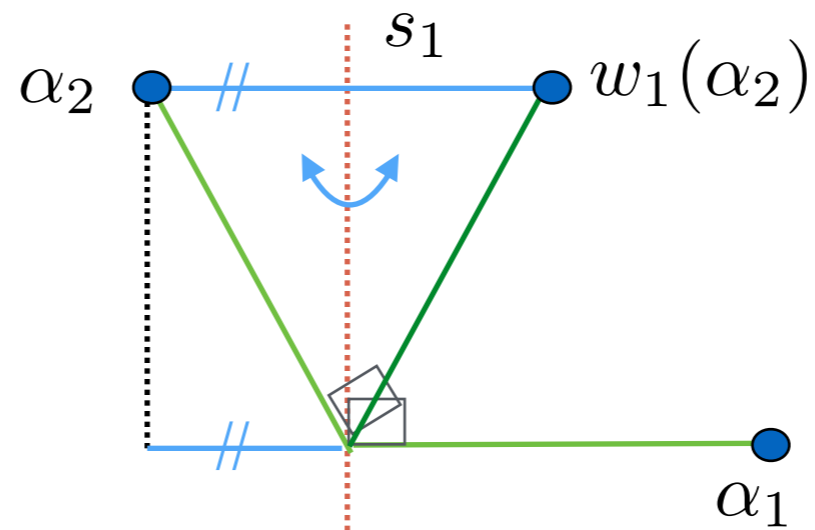

$$\begin{aligned}w_1(\alpha_2) &= \alpha_2 - 2 \frac{(\alpha_1, \alpha_2)}{(\alpha_1, \alpha_1)} \alpha_1 \\ &= (-1, \sqrt{3}) + (2, 0) \\ &= (1, \sqrt{3})\end{aligned}$$

Root System

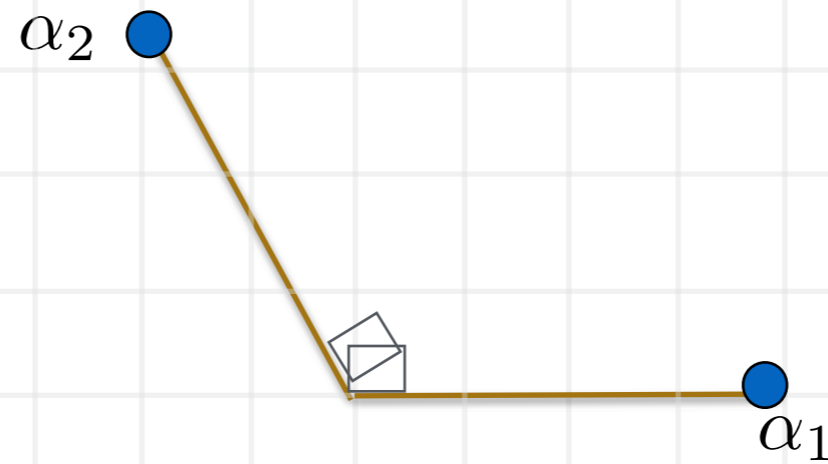

α_1 and α_2 are “simple” roots

Root System

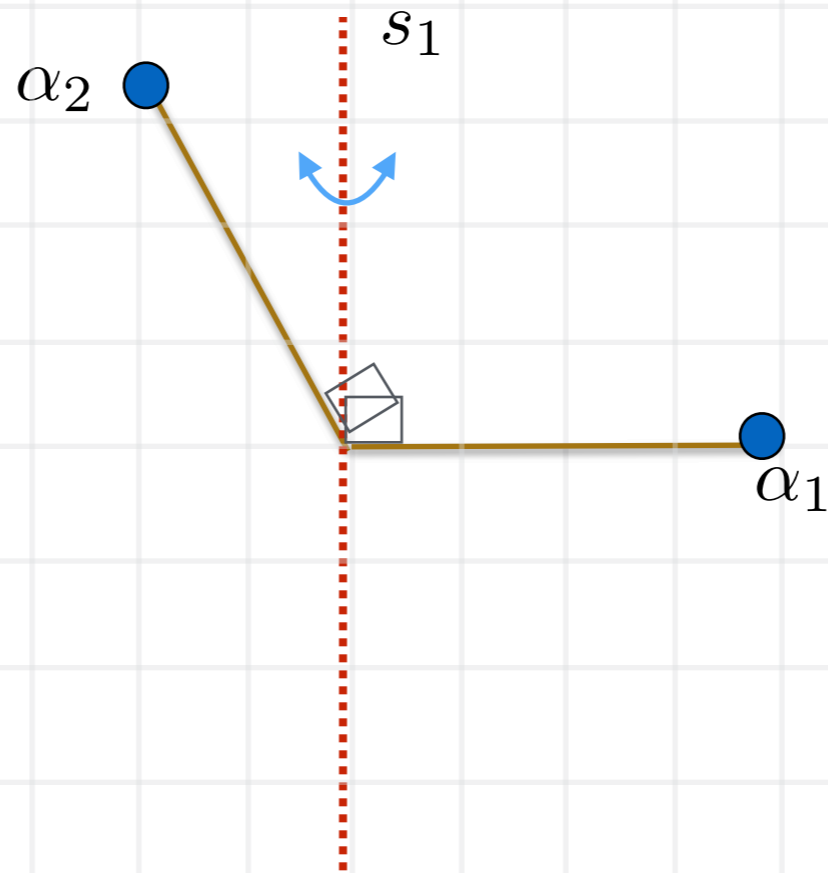

α_1 and α_2 are “simple” roots

Root System

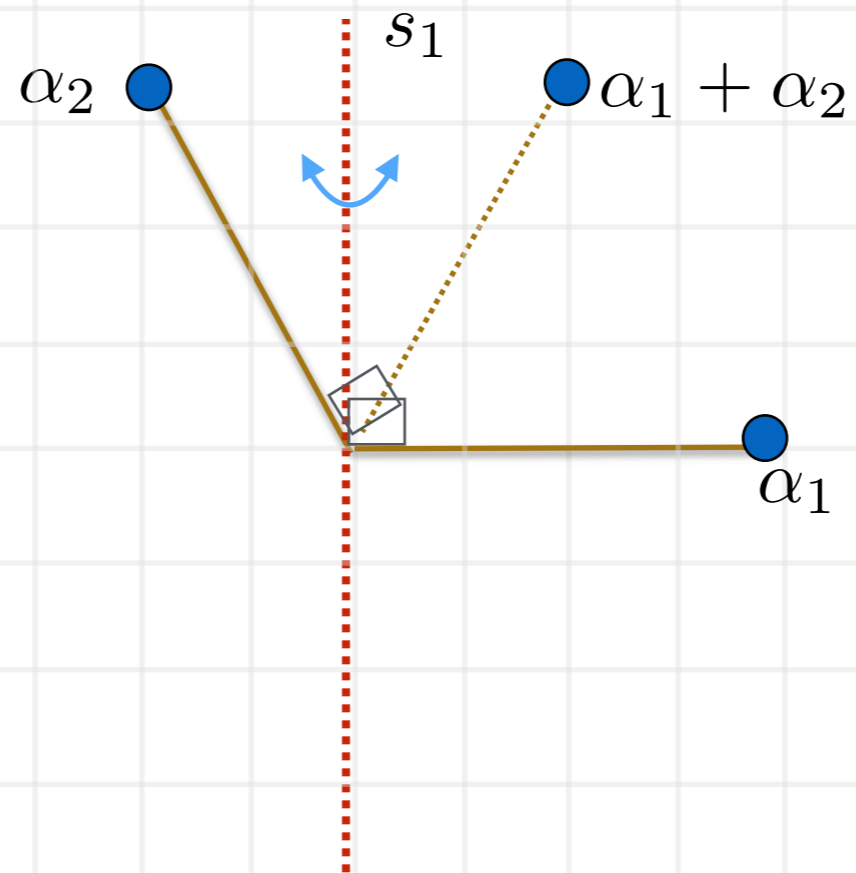

α_1 and α_2 are “simple” roots

Root System

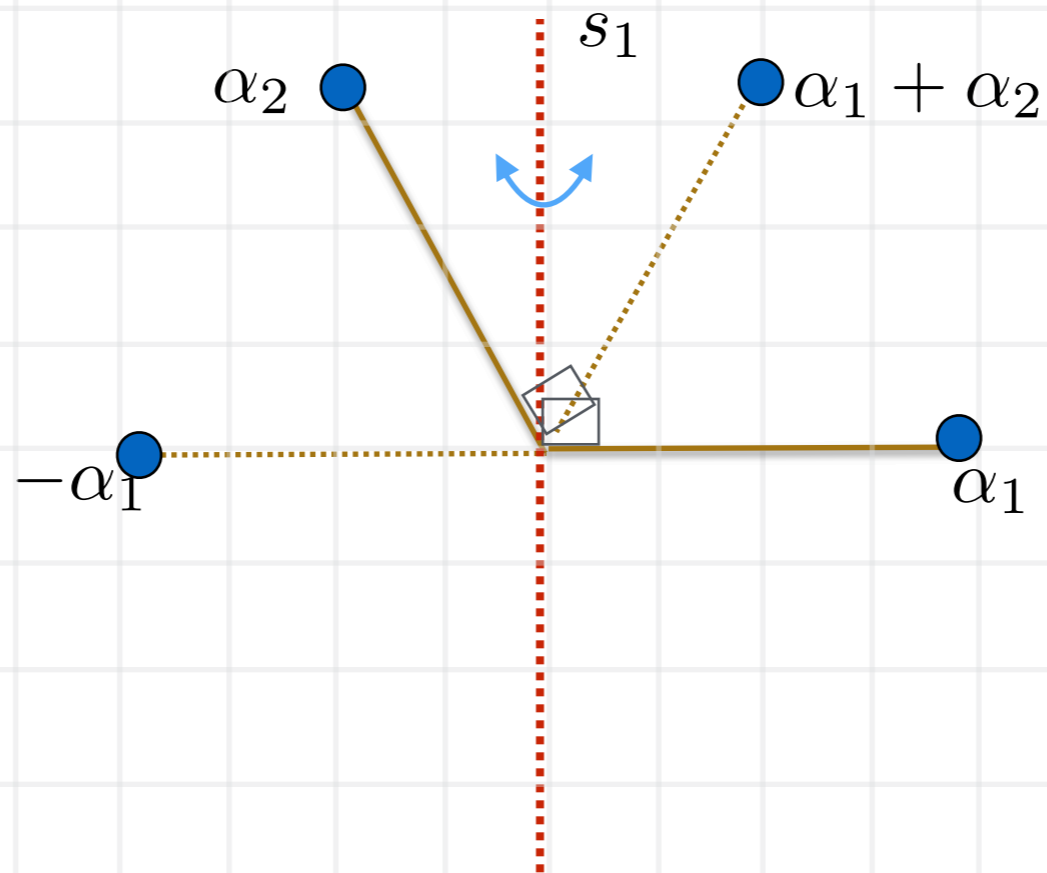

α_1 and α_2 are “simple” roots

Root System

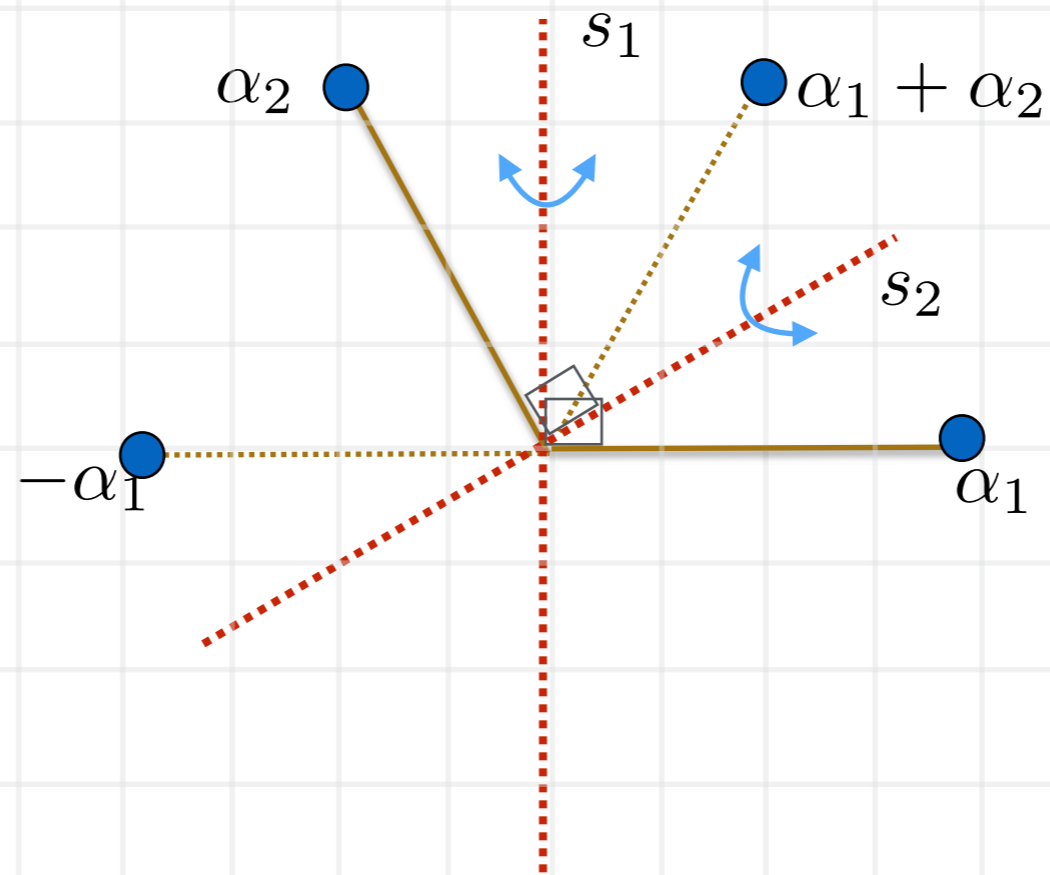

α_1 and α_2 are “simple” roots

Root System

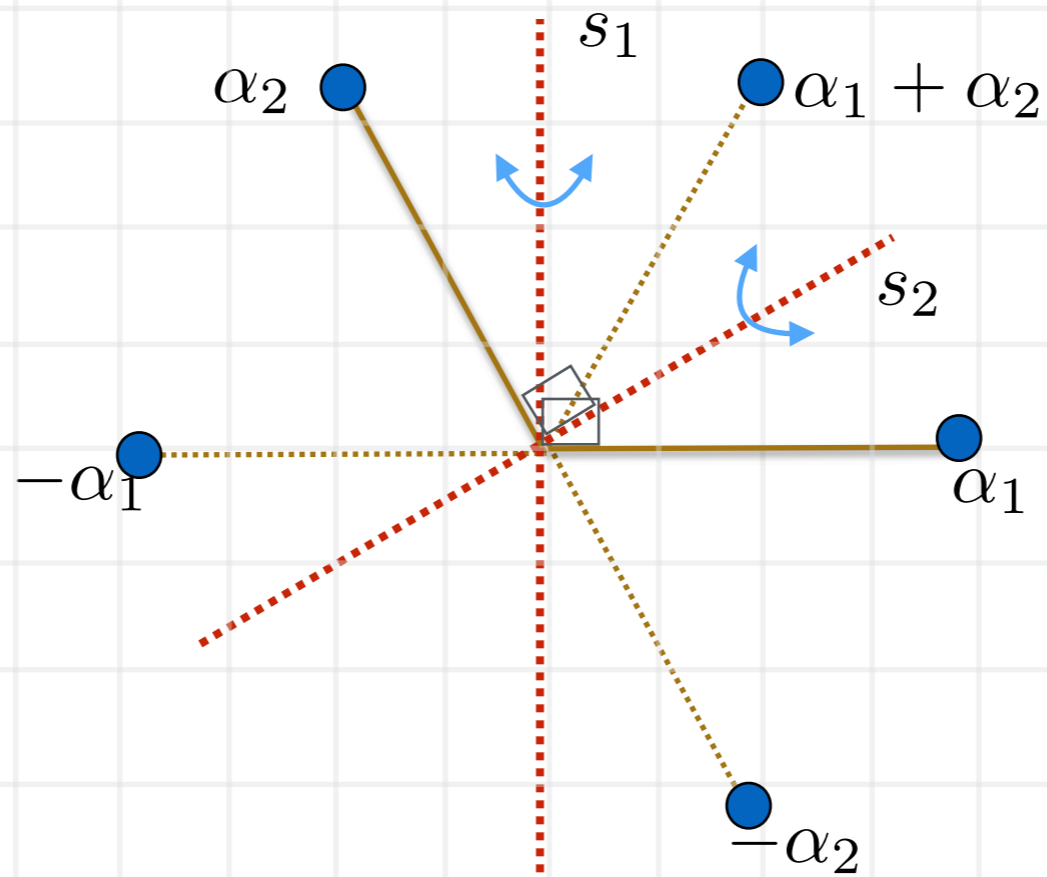

α_1 and α_2 are “simple” roots

Root System

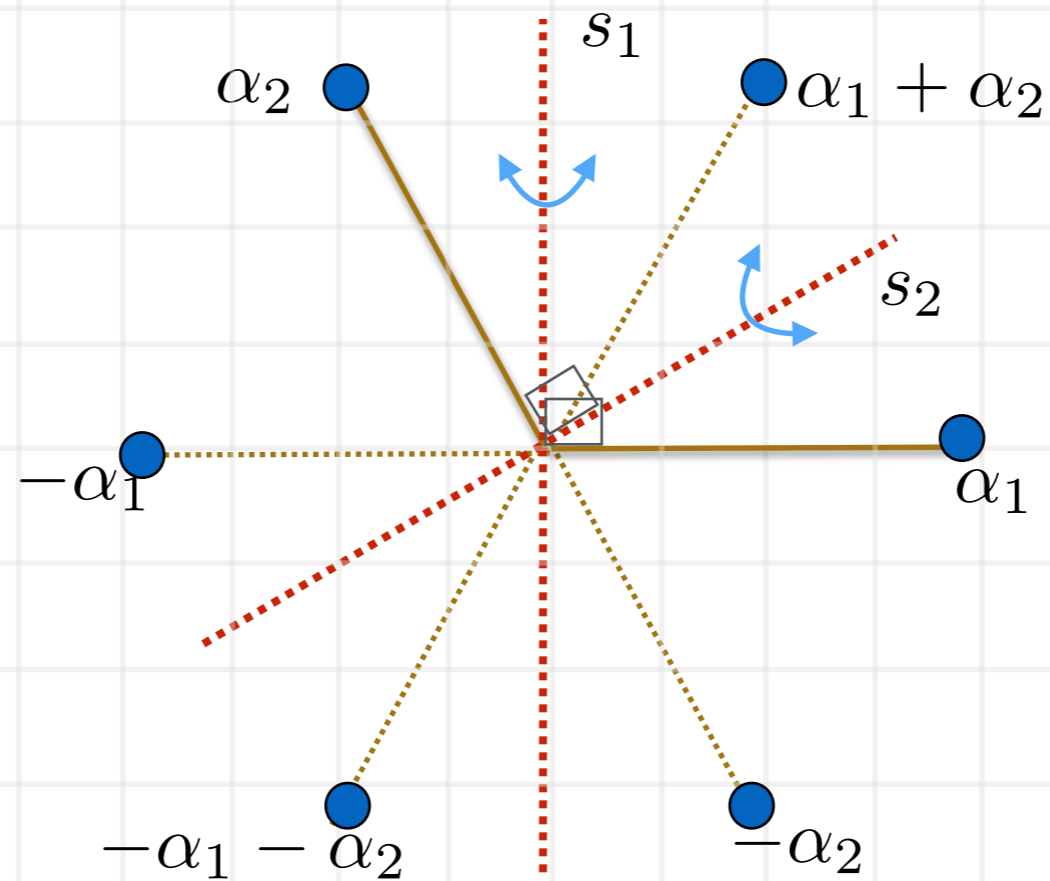

α_1 and α_2 are “simple” roots

Root System

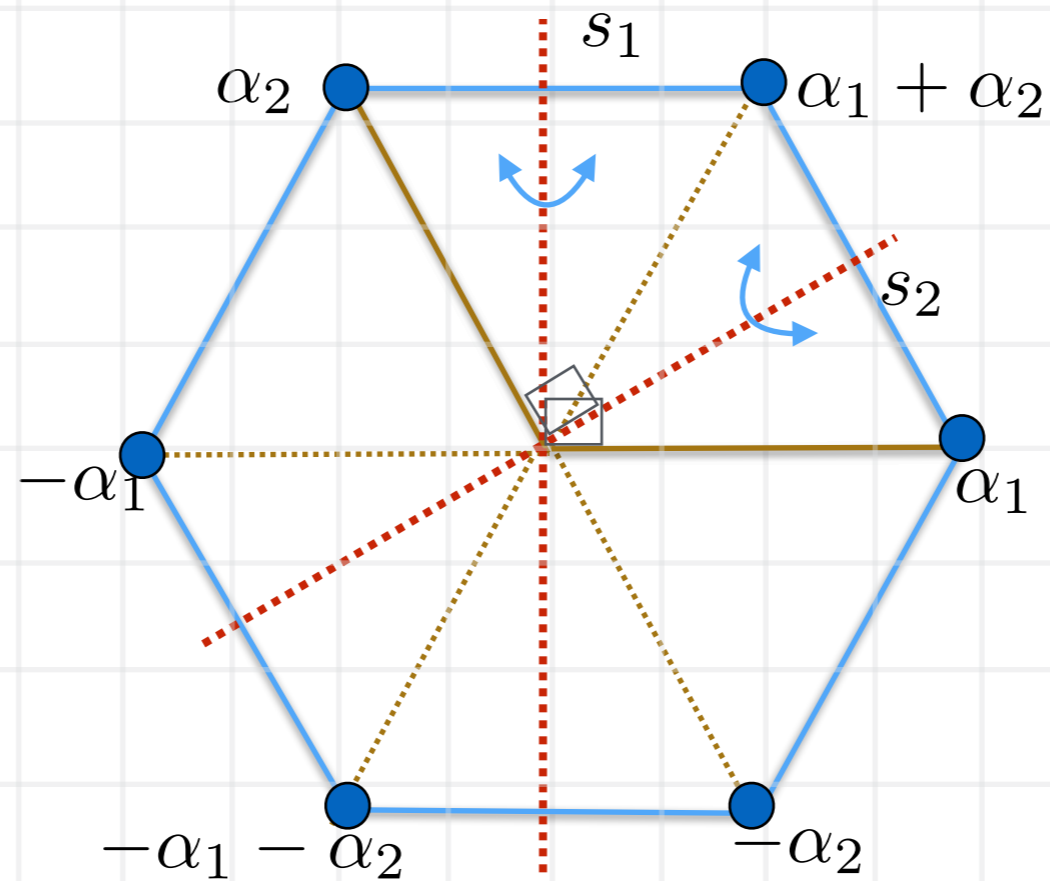

α_1 and α_2 are “simple” roots

Reflection Groups

- Roots: $\alpha_1, \alpha_2, \dots, \alpha_n$
- Reflections: $w_i(\alpha_j) = \alpha_j - 2 \frac{(\alpha_i, \alpha_j)}{(\alpha_i, \alpha_i)} \alpha_i$
- Co-roots: $\check{\alpha}_i = 2 \frac{\alpha_i}{(\alpha_i, \alpha_i)}$
- Weights: h_1, h_2, \dots, h_n
 $(h_i, \check{\alpha}_i) = \delta_{ij}$

A_2

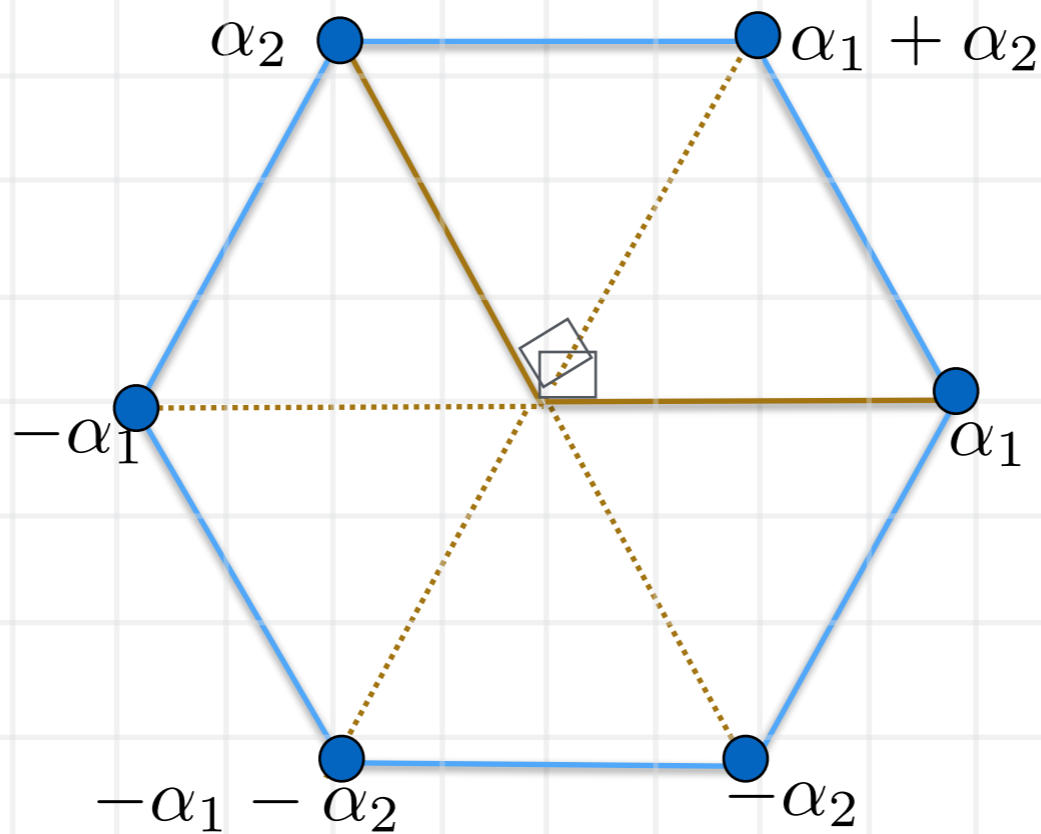

A_2

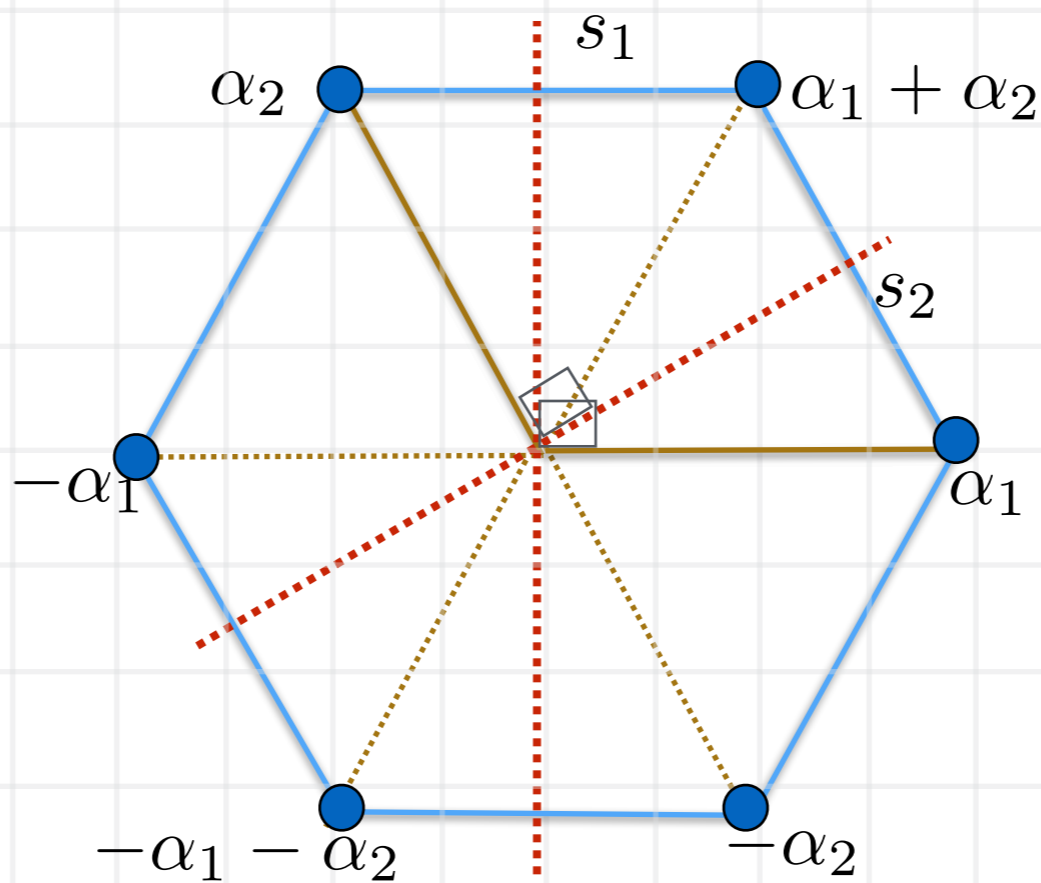

A_2

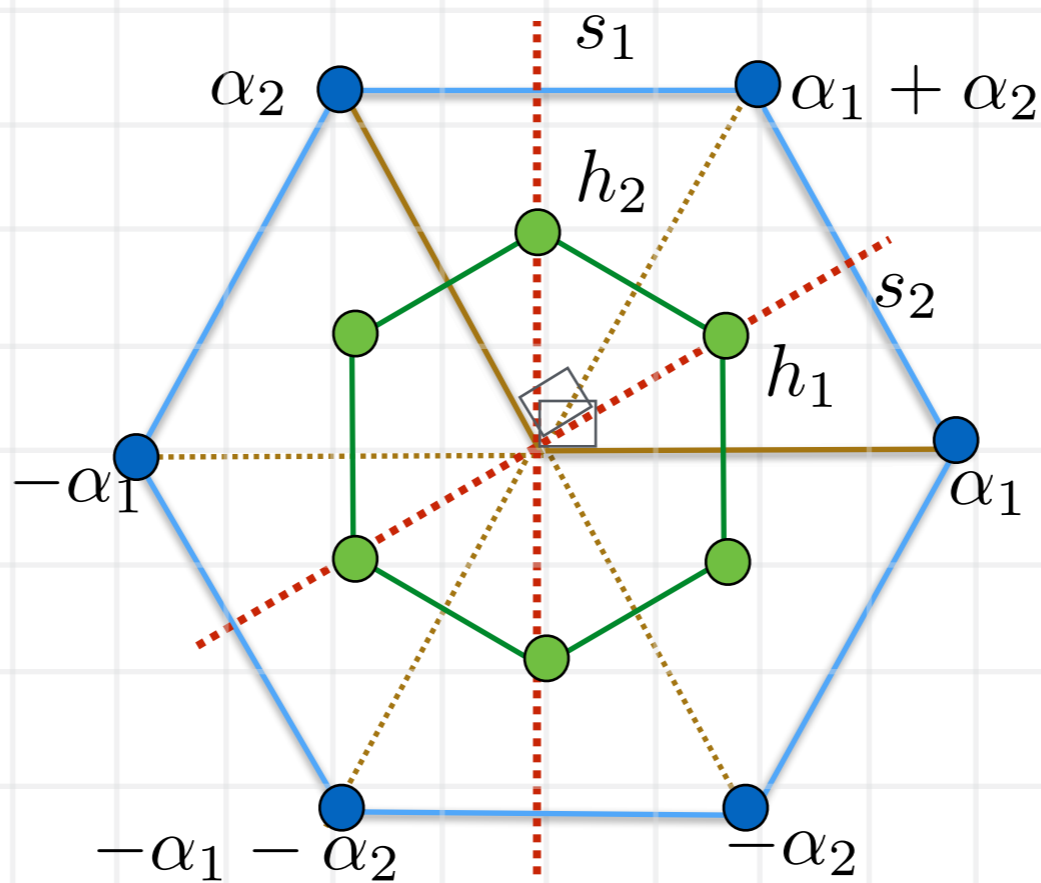

A_2

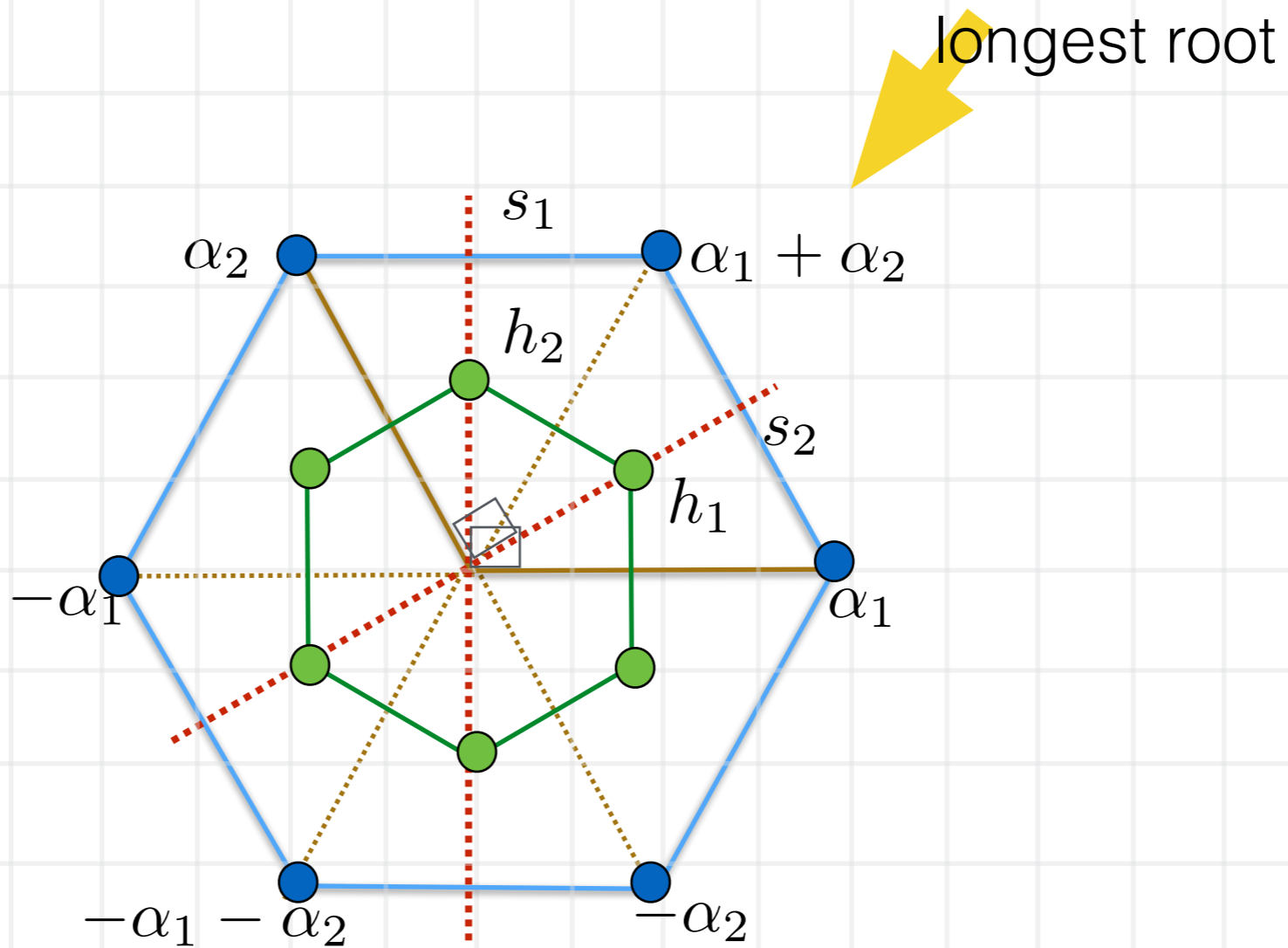

A_2

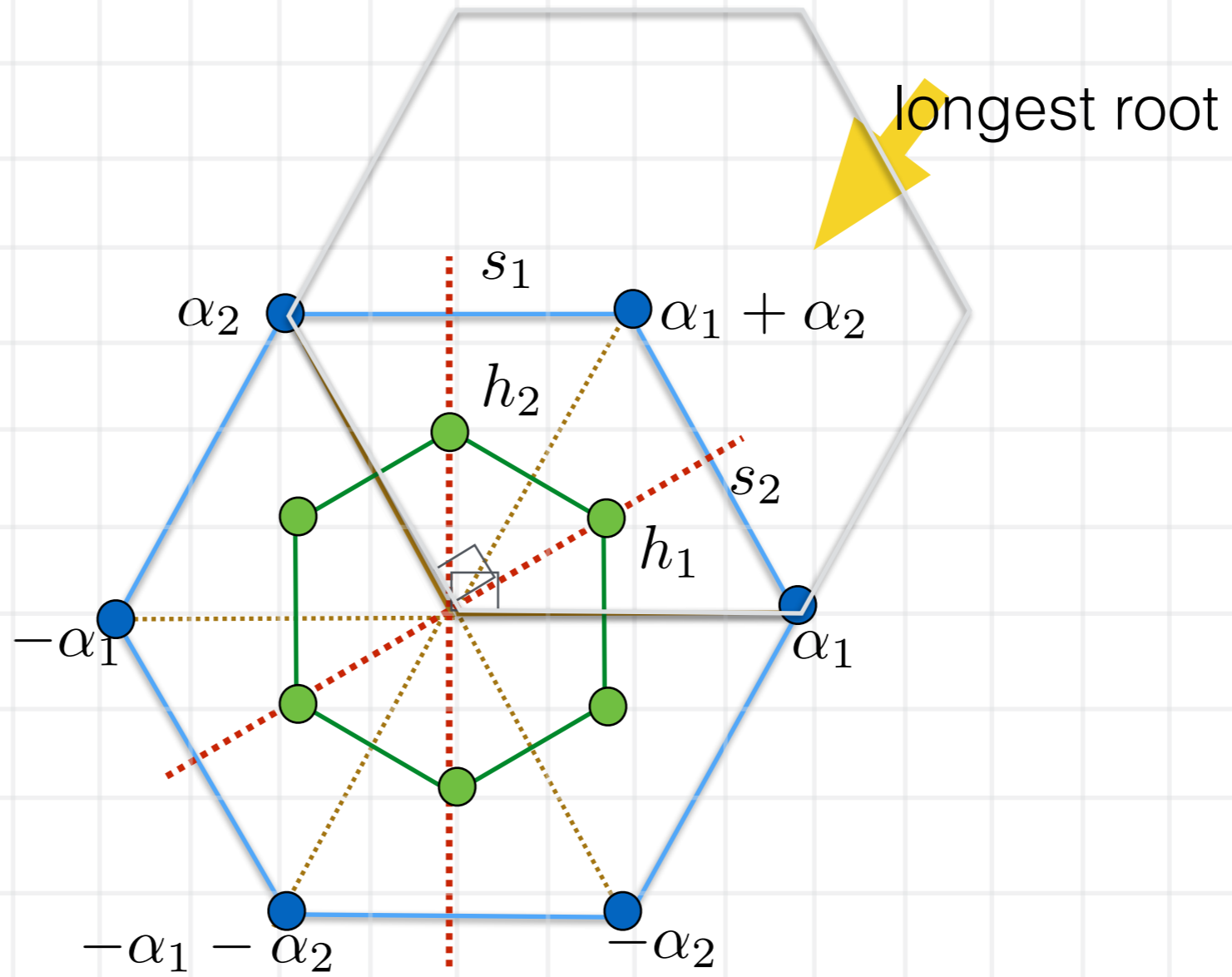

Translation by longest root

$A_2^{(1)}$

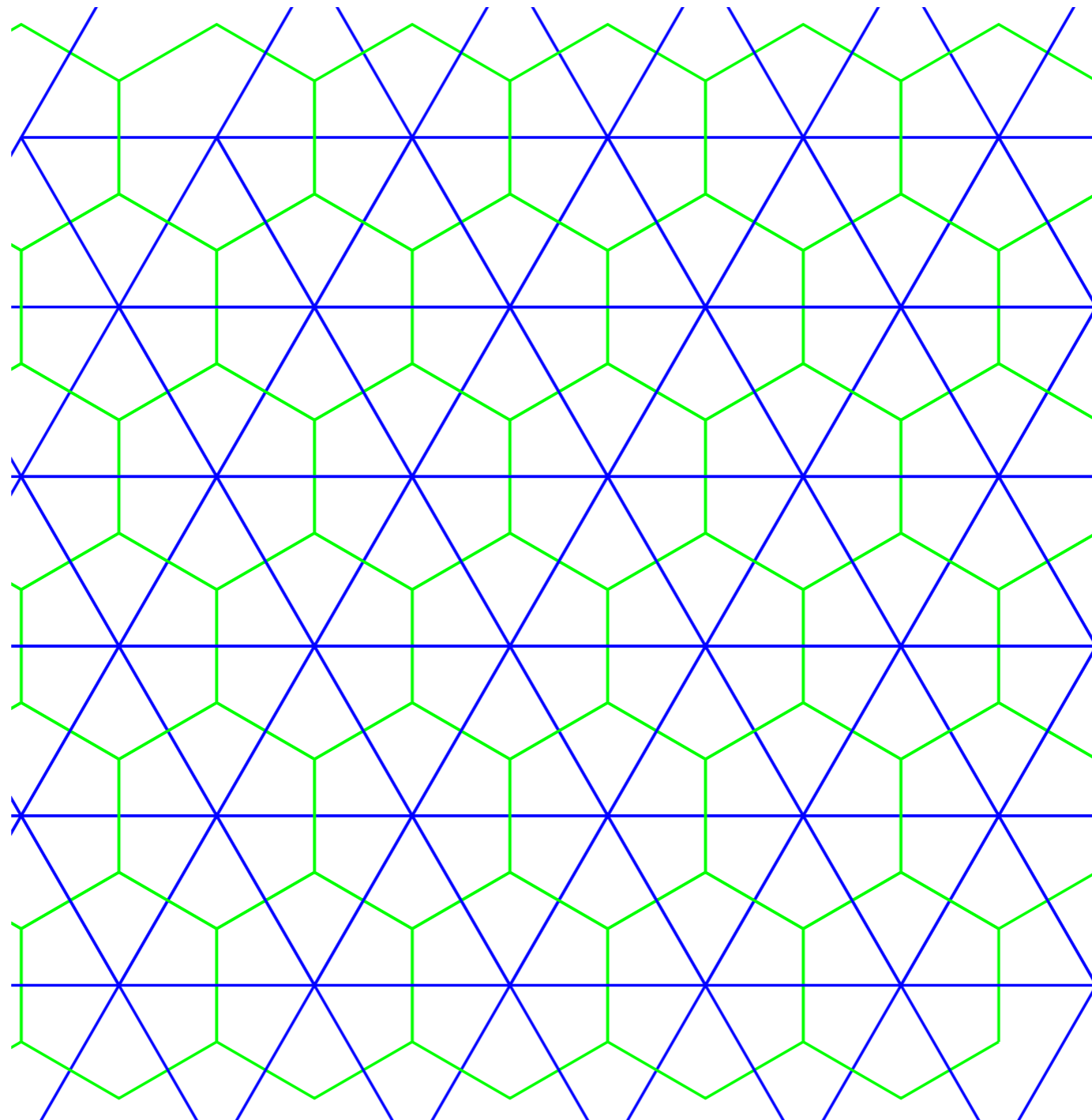

On the Lattice

$$\widetilde{\mathcal{W}}(A_2^{(1)}) = \langle s_0, s_1, s_2, \pi \rangle$$

$$s_j^2 = 1, \quad (s_j s_{j+1})^3 = 1, \quad (j = 0, 1, 2)$$

$$\pi^3 = 1, \quad \pi s_j = s_{j+1} \pi$$

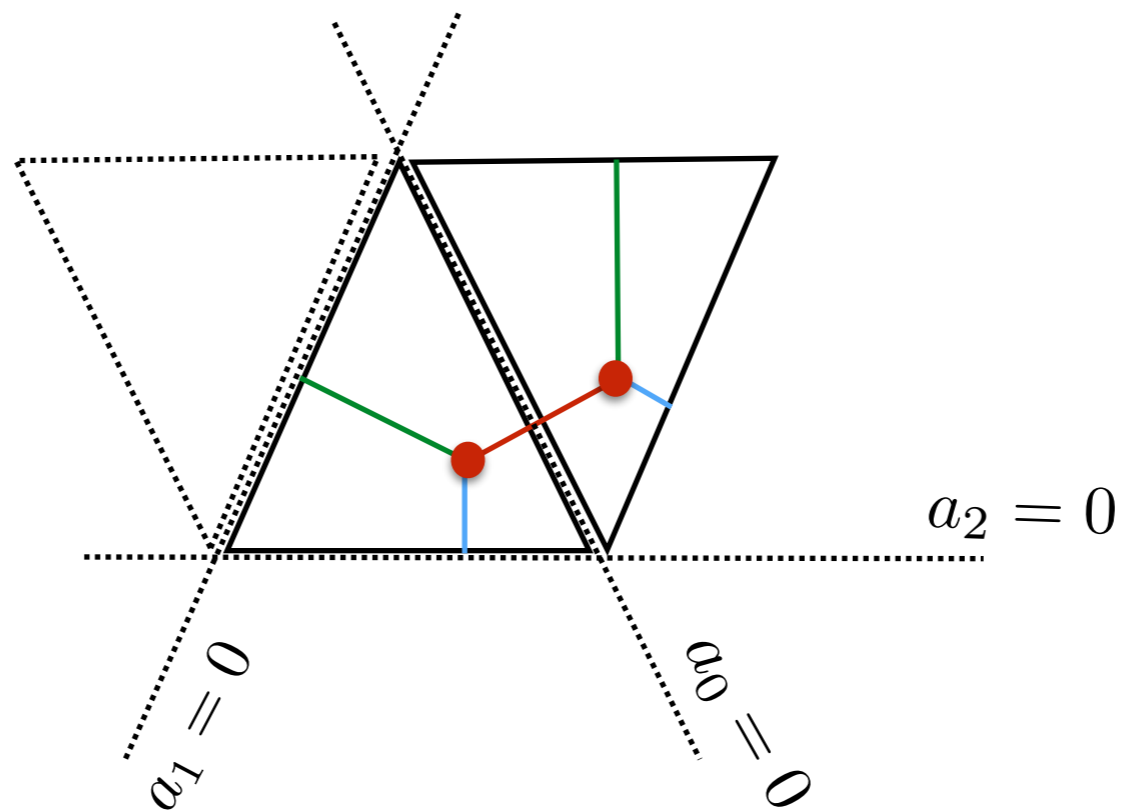

$$s_0(a_0, a_1, a_2) = (-a_0, a_1 + a_0, a_2 + a_0)$$

On the Lattice

$$\widetilde{\mathcal{W}}(A_2^{(1)}) = \langle s_0, s_1, s_2, \pi \rangle$$

$$s_j^2 = 1, \quad (s_j s_{j+1})^3 = 1, \quad (j = 0, 1, 2)$$

$$\pi^3 = 1, \quad \pi s_j = s_{j+1} \pi$$

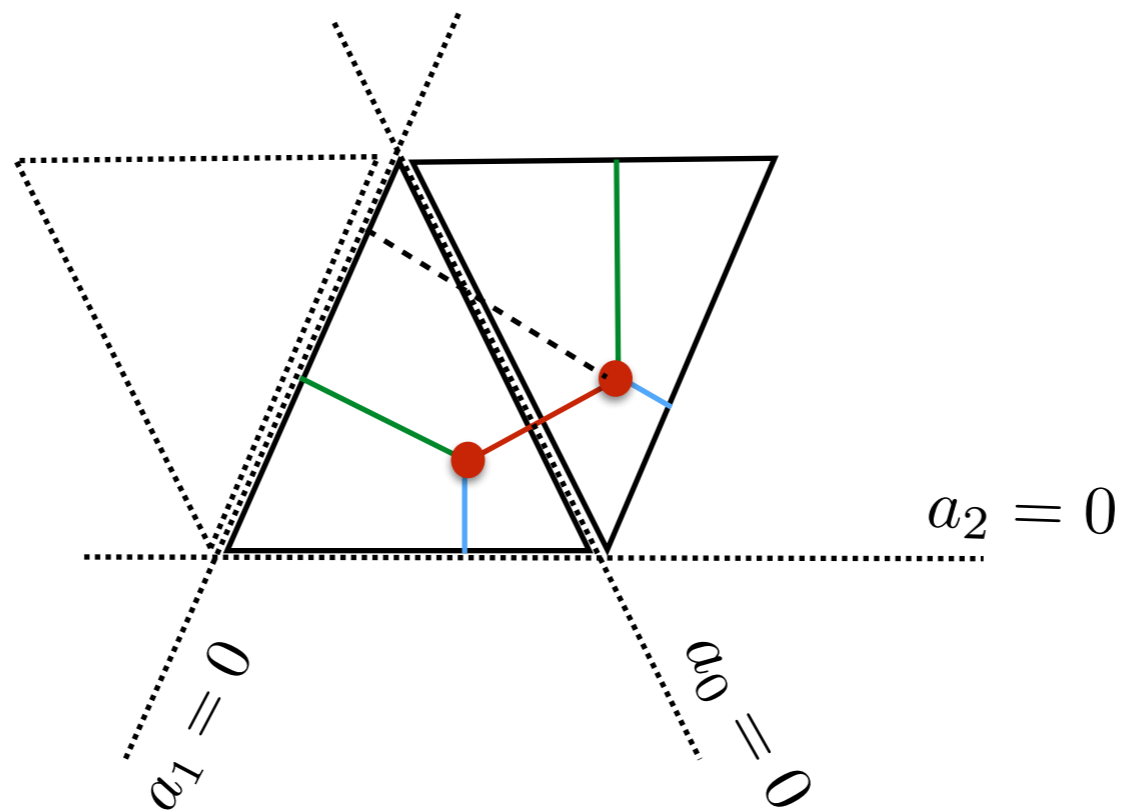

$$s_0(a_0, a_1, a_2) = (-a_0, a_1 + a_0, a_2 + a_0)$$

On the Lattice

$$\widetilde{\mathcal{W}}(A_2^{(1)}) = \langle s_0, s_1, s_2, \pi \rangle$$

$$s_j^2 = 1, \quad (s_j s_{j+1})^3 = 1, \quad (j = 0, 1, 2)$$

$$\pi^3 = 1, \quad \pi s_j = s_{j+1} \pi$$

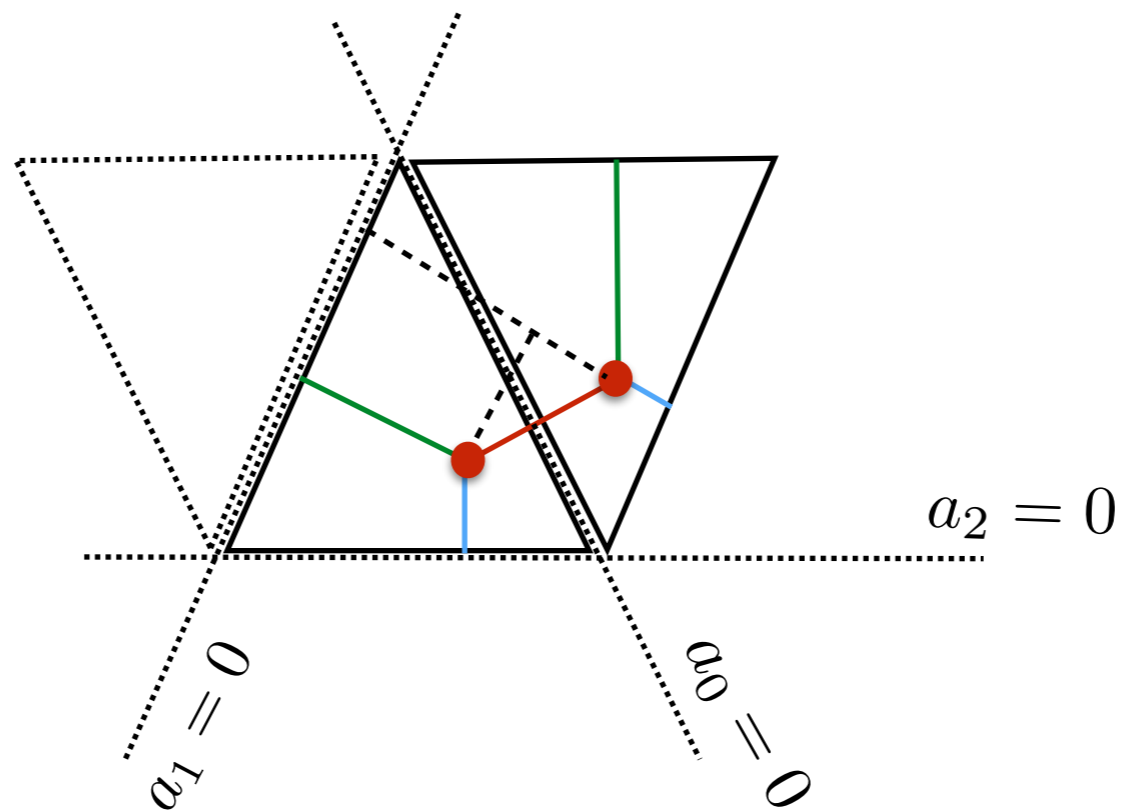

$$s_0(a_0, a_1, a_2) = (-a_0, a_1 + a_0, a_2 + a_0)$$

On the Lattice

$$\widetilde{\mathcal{W}}(A_2^{(1)}) = \langle s_0, s_1, s_2, \pi \rangle$$

$$s_j^2 = 1, \quad (s_j s_{j+1})^3 = 1, \quad (j = 0, 1, 2)$$

$$\pi^3 = 1, \quad \pi s_j = s_{j+1} \pi$$

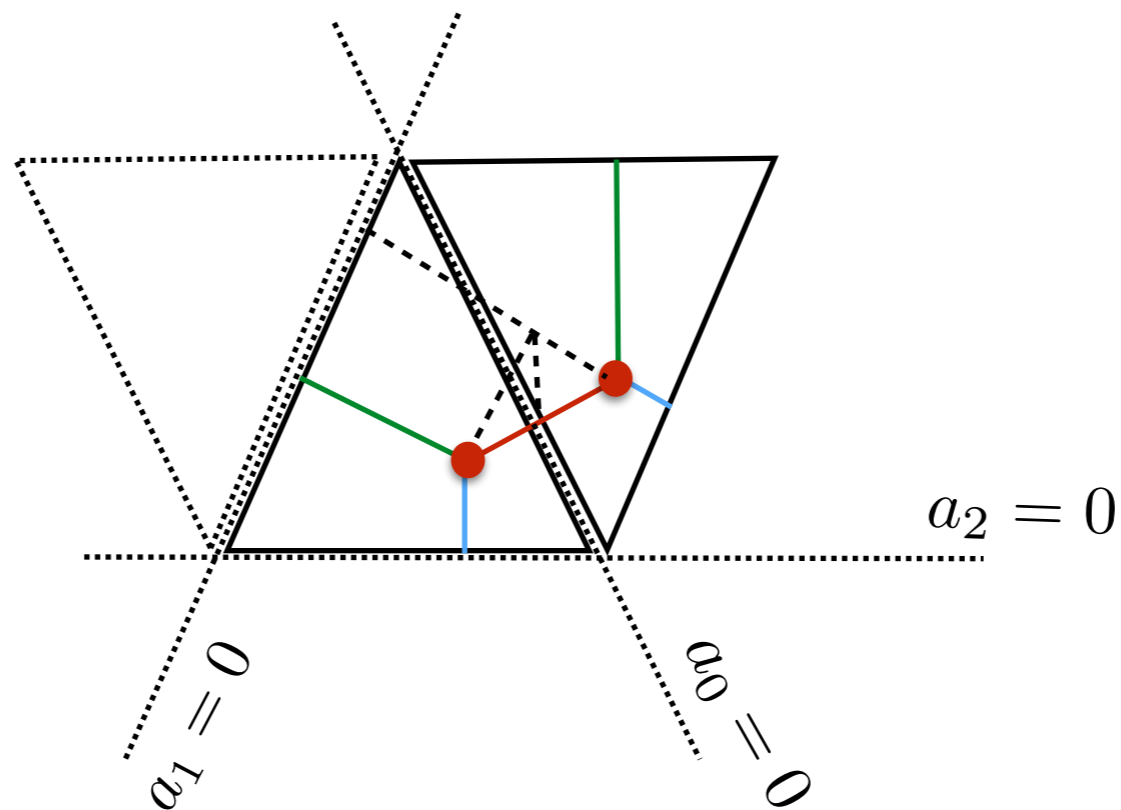

$$s_0(a_0, a_1, a_2) = (-a_0, a_1 + a_0, a_2 + a_0)$$

On the Lattice

$$\widetilde{\mathcal{W}}(A_2^{(1)}) = \langle s_0, s_1, s_2, \pi \rangle$$

$$s_j^2 = 1, \quad (s_j s_{j+1})^3 = 1, \quad (j = 0, 1, 2)$$

$$\pi^3 = 1, \quad \pi s_j = s_{j+1} \pi$$

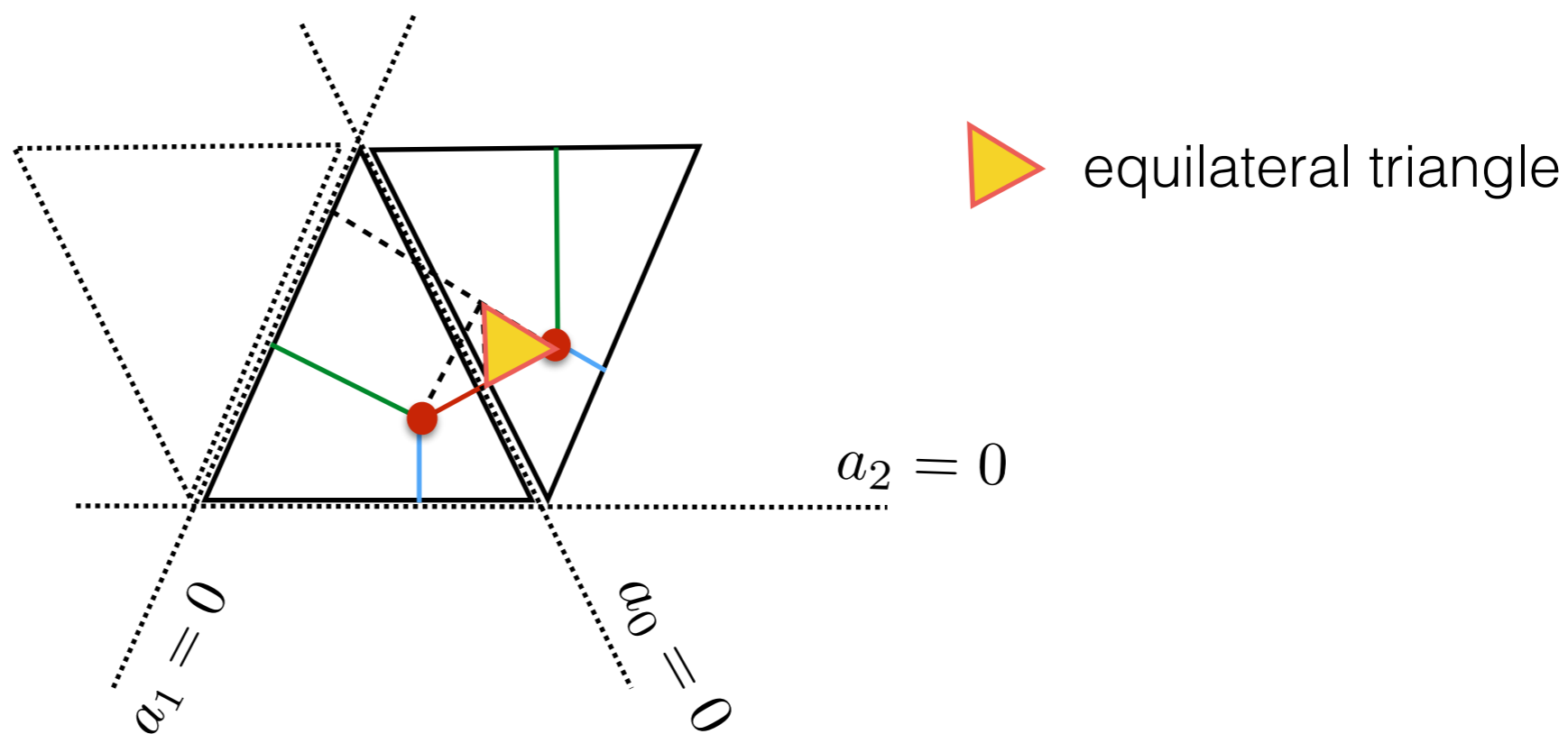

$$s_0(a_0, a_1, a_2) = (-a_0, a_1 + a_0, a_2 + a_0)$$

On the Lattice

$$\widetilde{\mathcal{W}}(A_2^{(1)}) = \langle s_0, s_1, s_2, \pi \rangle$$

$$s_j^2 = 1, \quad (s_j s_{j+1})^3 = 1, \quad (j = 0, 1, 2)$$

$$\pi^3 = 1, \quad \pi s_j = s_{j+1} \pi$$

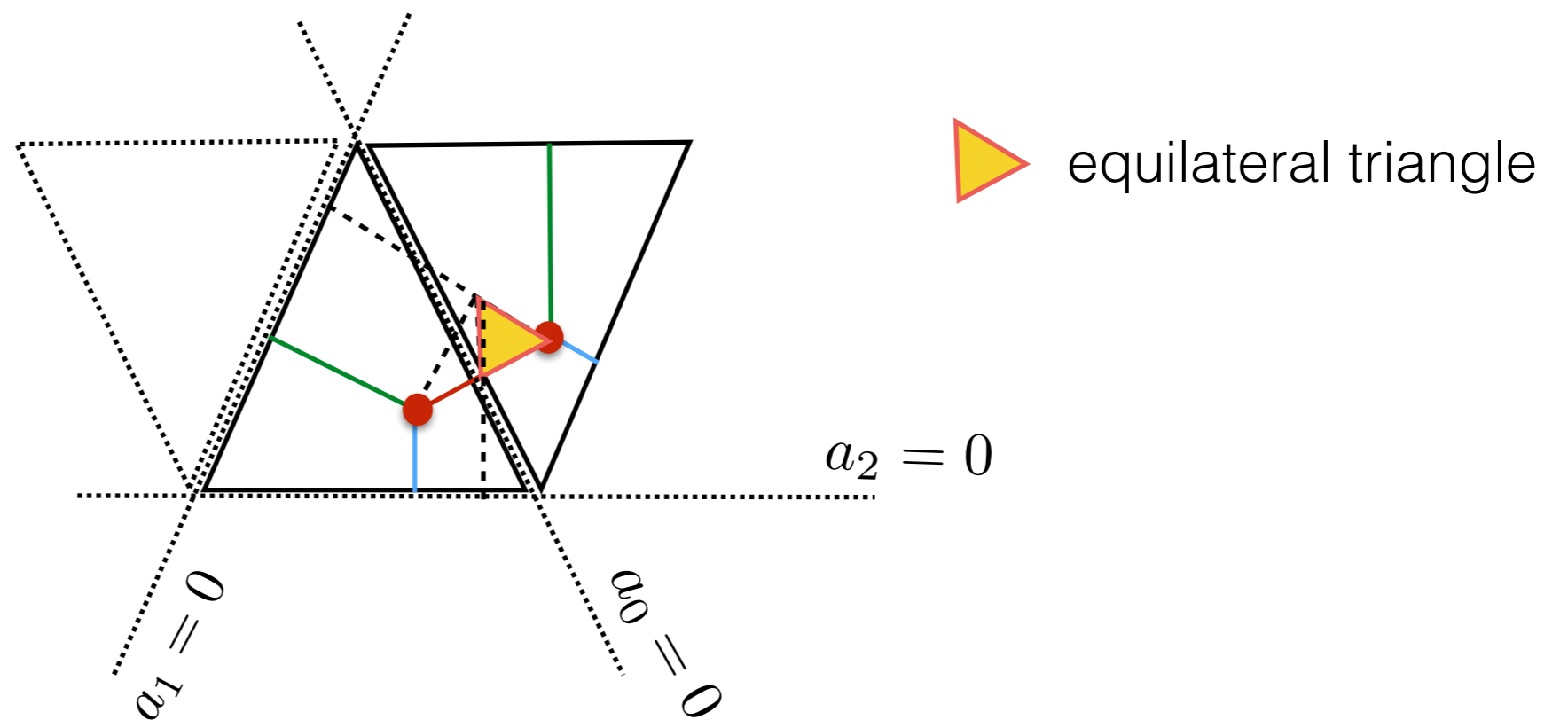

$$s_0(a_0, a_1, a_2) = (-a_0, a_1 + a_0, a_2 + a_0)$$

Cremona Isometries

	a_0	a_1	a_2	f_0	f_1	f_2
s_0	$-a_0$	$a_1 + a_0$	$a_2 + a_0$	f_0	$f_1 + \frac{a_0}{f_0}$	$f_2 - \frac{a_0}{f_0}$
s_1	$a_0 + a_1$	$-a_1$	$a_2 + a_1$	$f_0 - \frac{a_1}{f_1}$	f_1	$f_2 - \frac{a_1}{f_1}$
s_2	$a_0 + a_2$	$a_1 + a_2$	$-a_2$	$f_0 + \frac{a_2}{f_2}$	$f_1 - \frac{a_2}{f_1}$	f_2

Cremona Isometries

	a_0	a_1	a_2	f_0	f_1	f_2
s_0	$-a_0$	$a_1 + a_0$	$a_2 + a_0$	f_0	$f_1 + \frac{a_0}{f_0}$	$f_2 - \frac{a_0}{f_0}$
s_1	$a_0 + a_1$	$-a_1$	$a_2 + a_1$	$f_0 - \frac{a_1}{f_1}$	f_1	$f_2 - \frac{a_1}{f_1}$
s_2	$a_0 + a_2$	$a_1 + a_2$	$-a_2$	$f_0 + \frac{a_2}{f_2}$	$f_1 - \frac{a_2}{f_1}$	f_2

Discrete Dynamics I

- Translation

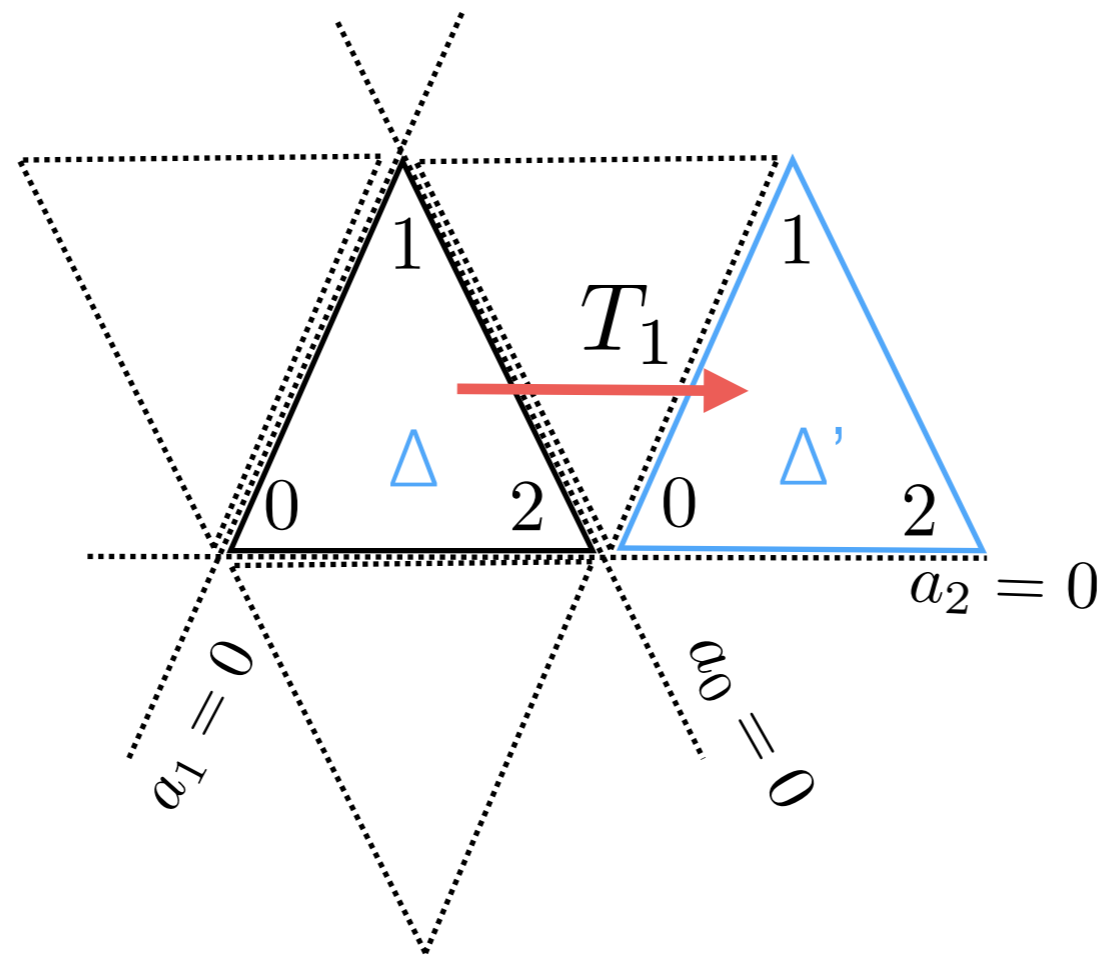

Discrete Dynamics II

- Translation as reflections ?

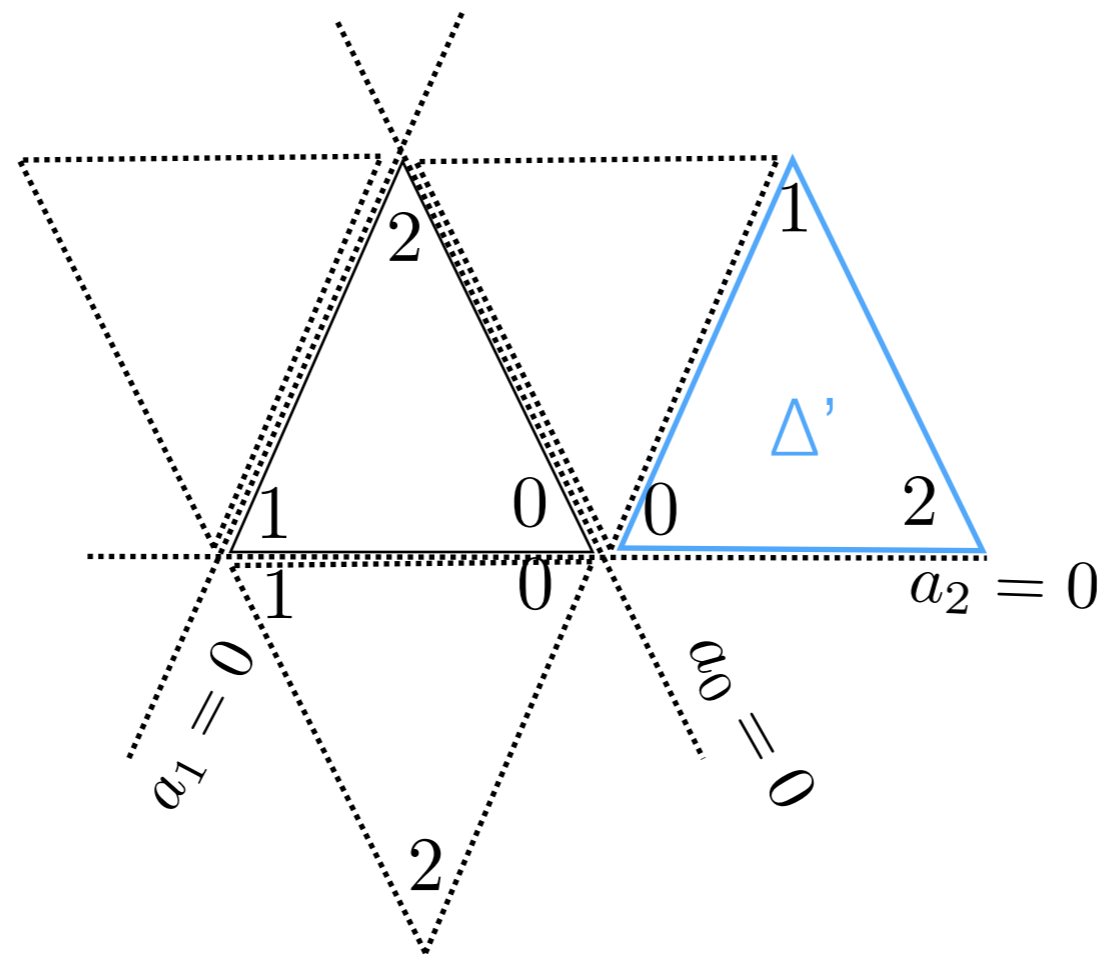

Discrete Dynamics II

- Translation as reflections ?

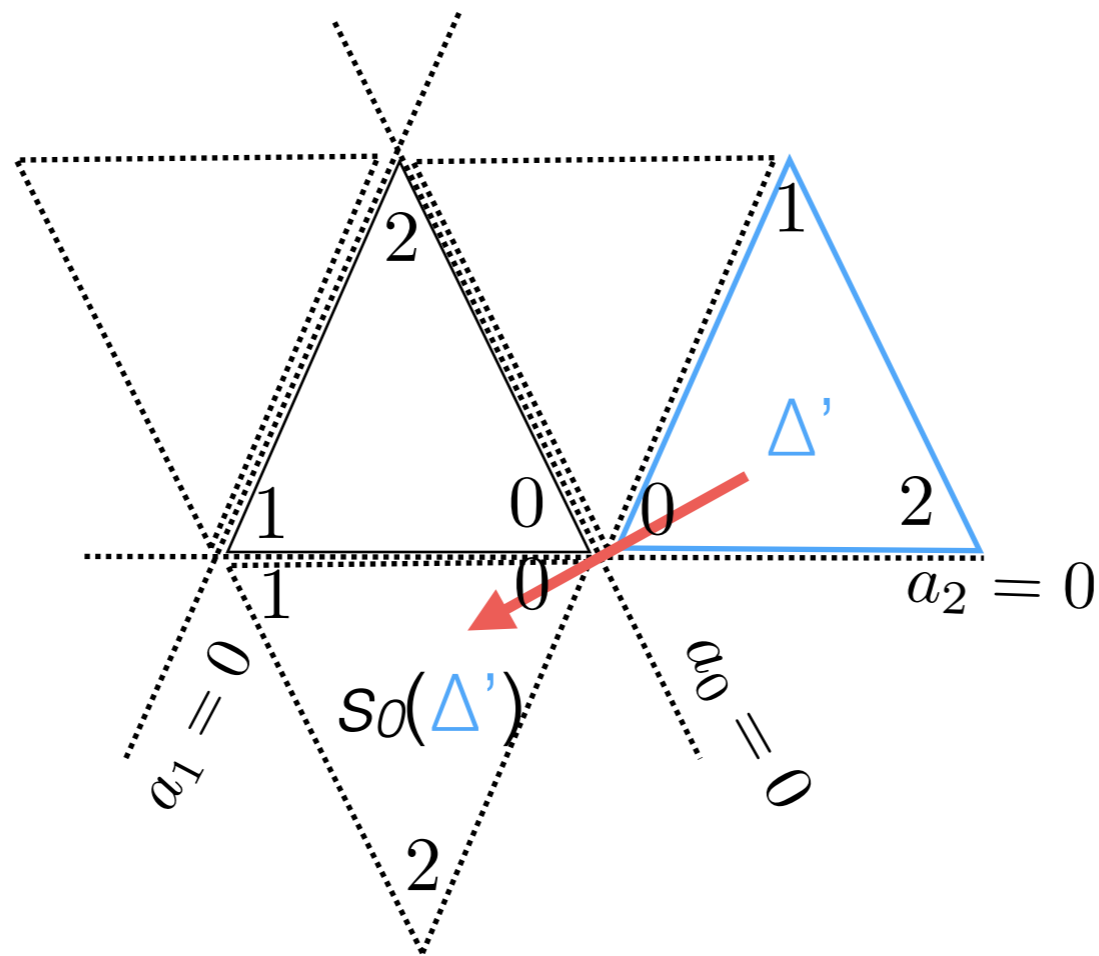

Discrete Dynamics II

- Translation as reflections ?

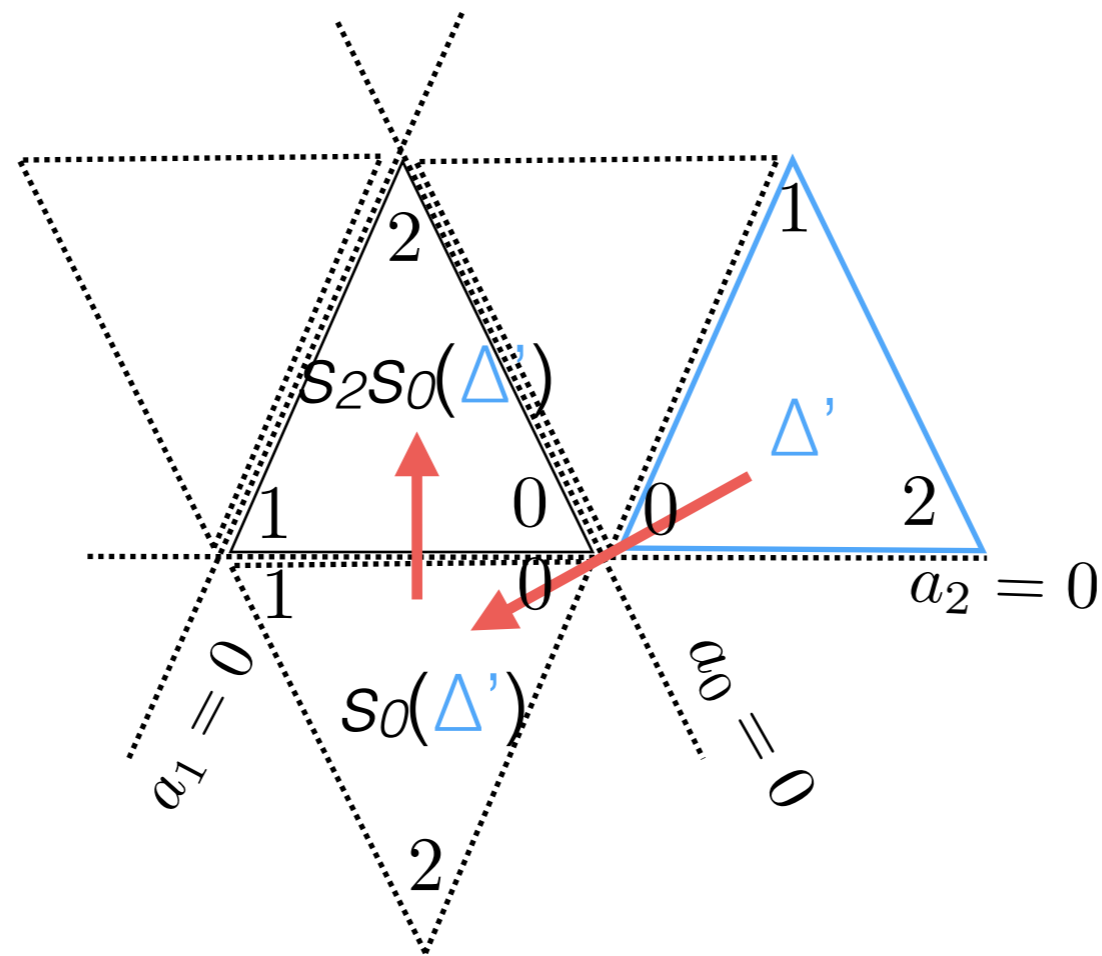

Discrete Dynamics III

- Translation as reflection + diagram automorphism

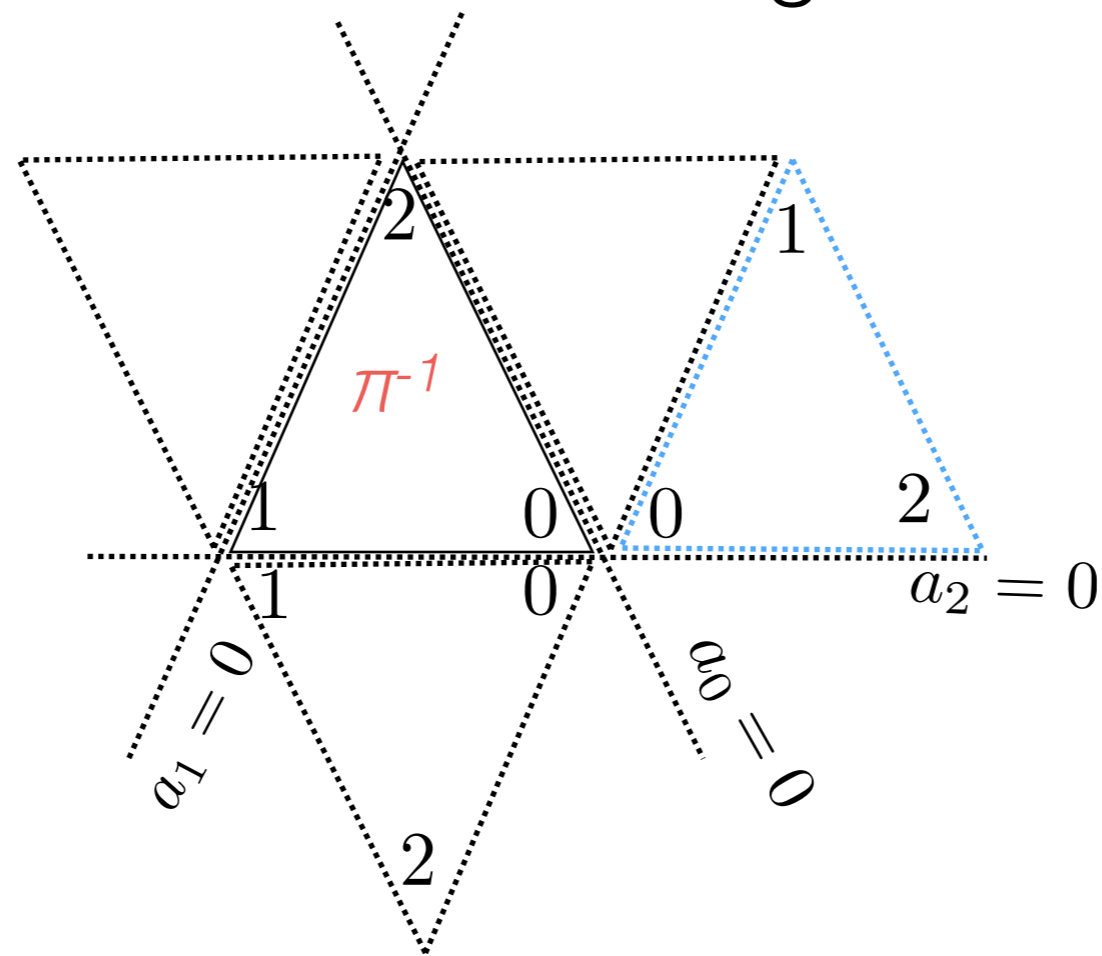

$$I = \pi^{-1} s_2 s_0 T_1 \text{ where } \pi^3 = 1 \Rightarrow T_1 = \pi s_2 s_1$$

Discrete Dynamics III

- Translation as reflection + diagram automorphism

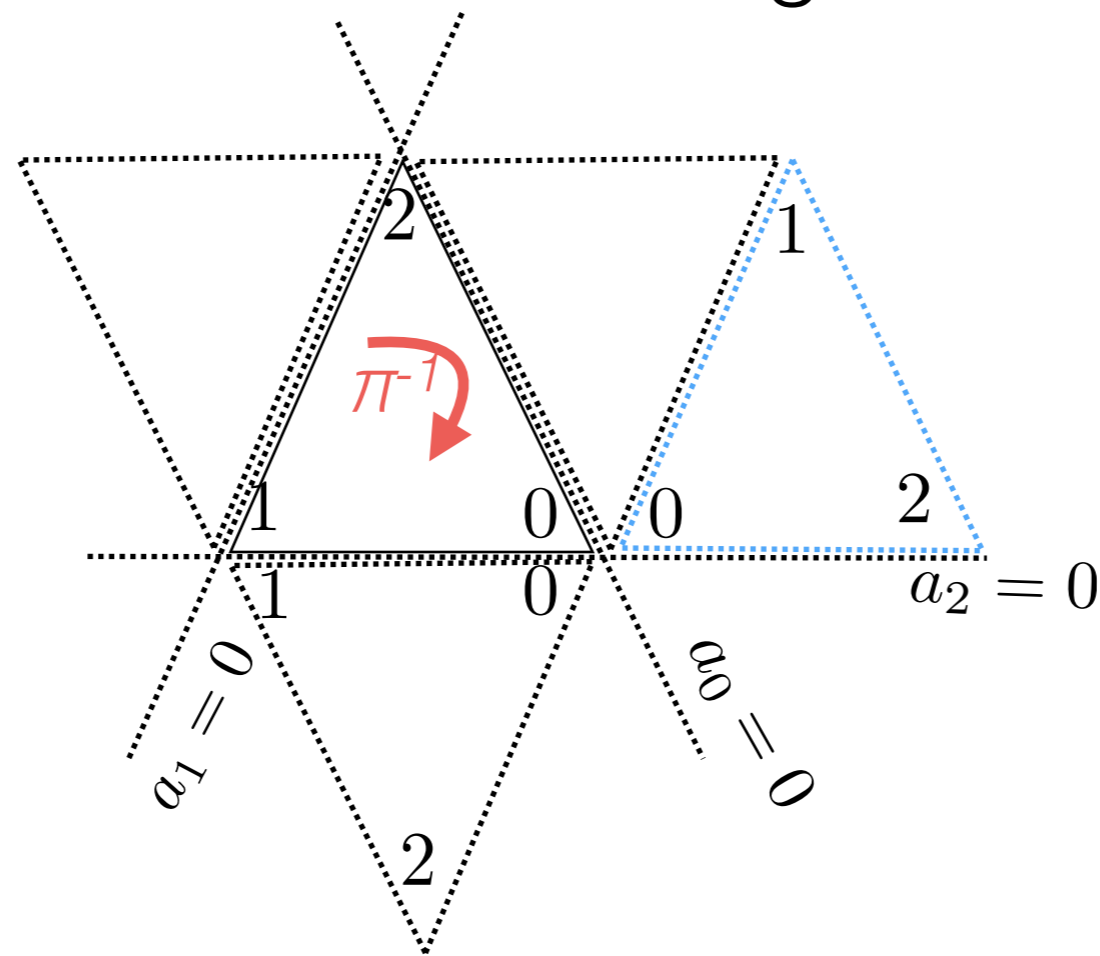

$$I = \pi^{-1} s_2 s_0 T_1 \text{ where } \pi^3 = 1 \Rightarrow T_1 = \pi s_2 s_1$$

Discrete Dynamics III

- Translation as reflection + diagram automorphism

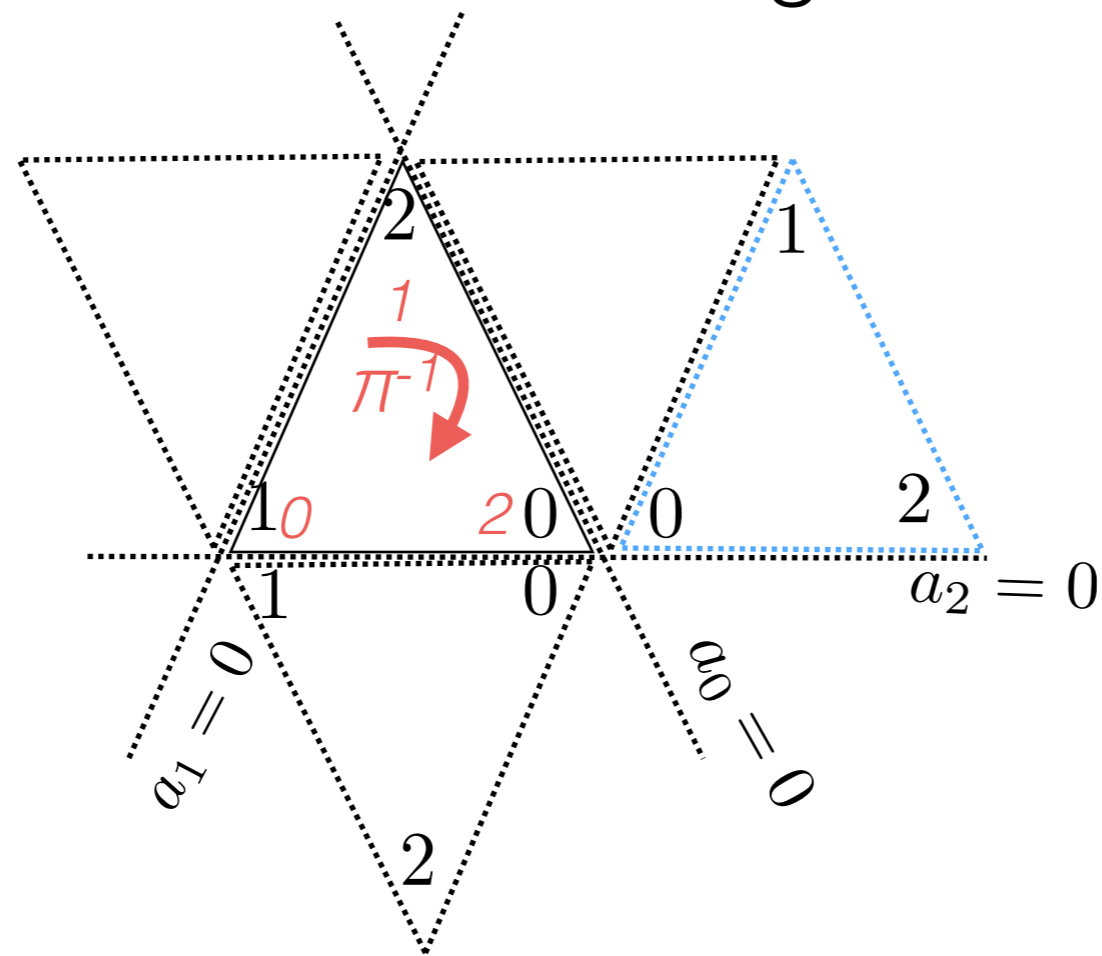

$$I = \pi^{-1} s_2 s_0 T_1 \text{ where } \pi^3 = 1 \Rightarrow T_1 = \pi s_2 s_1$$

Discrete Dynamics IV

Noting that

$$T_1(a_0) = a_0 + 1, T_1(a_1) = a_1 - 1, T_1(a_2) = a_2$$

Define

$$u_n = T_1^n(f_1), v_n = T_1^n(f_0)$$

$$\Rightarrow \begin{cases} u_n + u_{n+1} &= t - v_n - \frac{a_0 + n}{v_n} \\ v_n + v_{n-1} &= t - u_n + \frac{a_1 - n}{u_n} \end{cases}$$

Discrete Dynamics IV

Noting that

$$T_1(a_0) = a_0 + 1, T_1(a_1) = a_1 - 1, T_1(a_2) = a_2$$

Define

$$u_n = T_1^n(f_1), v_n = T_1^n(f_0)$$

$$\Rightarrow \begin{cases} u_n + u_{n+1} &= t - v_n - \frac{a_0 + n}{v_n} \\ v_n + v_{n-1} &= t - u_n + \frac{a_1 - n}{u_n} \end{cases}$$

These are **discrete Painlevé** equations.

What does this have to do with applied
mathematics?

Dynamical Systems

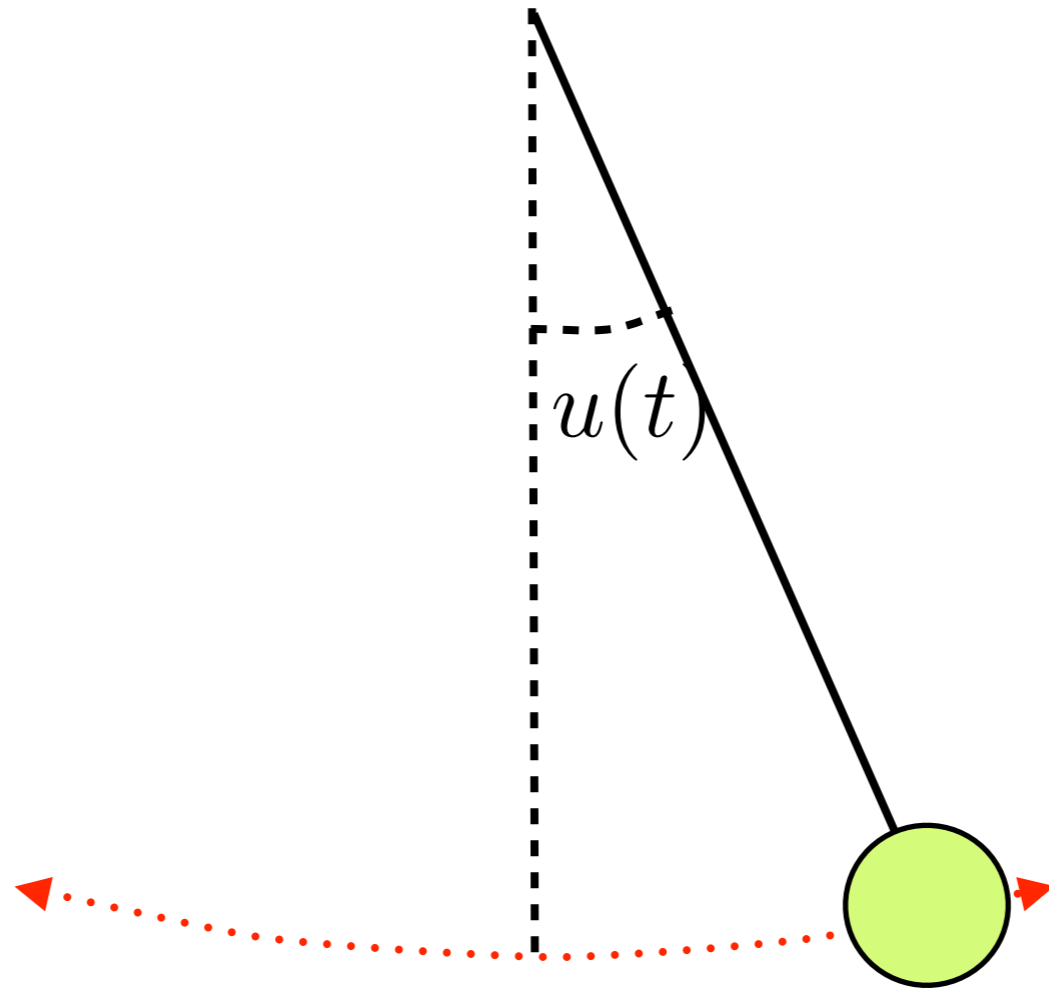

$$\begin{cases} \dot{u}(t) = v(t) \\ \dot{v}(t) = -\sin(u(t)) \end{cases}$$

Phase Space

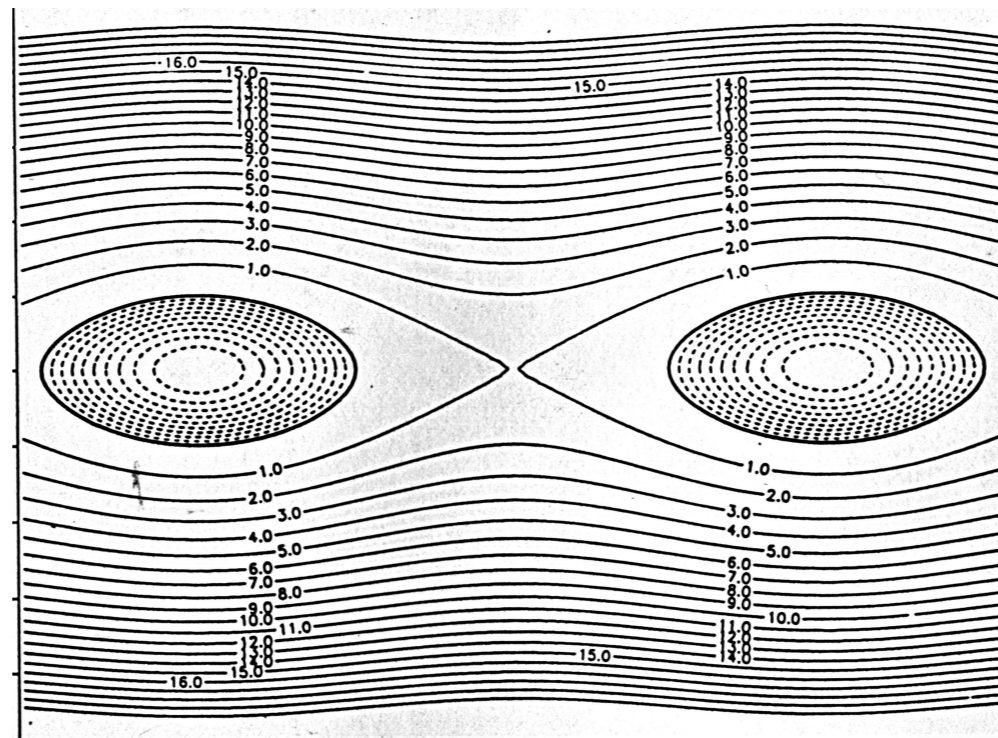

$$H(u, v) = \frac{v^2}{2} - \cos(u(t))$$

Another View

$$f(t) = e^{iu(t)}$$

$$\Rightarrow \begin{cases} \ddot{f} &= \frac{\dot{f}^2}{f} - \frac{1}{2} (f^2 - 1) \\ E &= \frac{\dot{f}^2}{2f^2} + \frac{1}{2} \left(f + \frac{1}{f} \right) \end{cases}$$

$$\Rightarrow \dot{f}^2 = -f^3 - 2E f^2 - 1$$

Phase Curves Again

$$y^2 = -x(x - E_+)(x - E_-)$$

$$E_{\pm} = E \pm \sqrt{E^2 - 1}$$

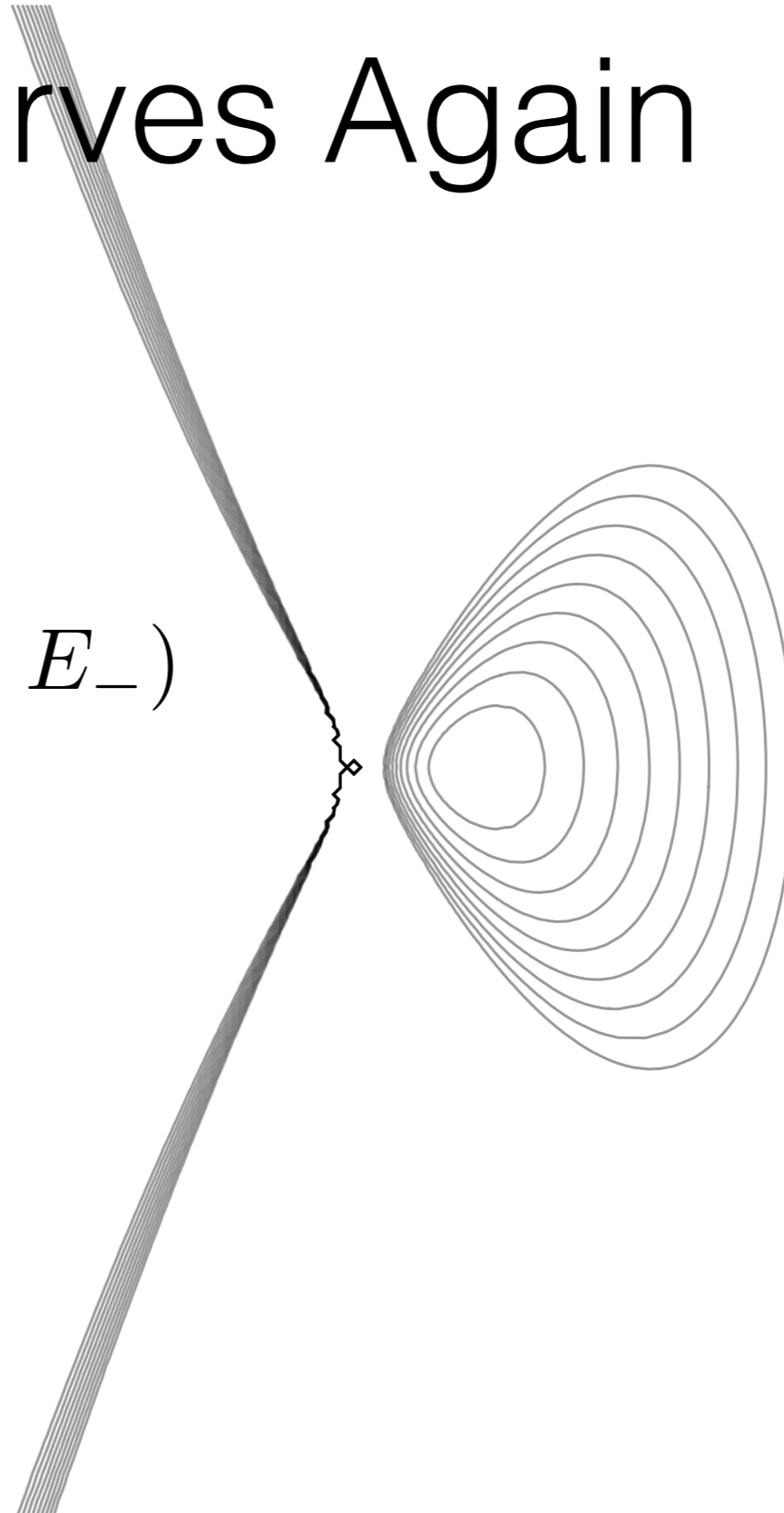

Phase Curves Again

$$y^2 = -x(x - E_+)(x - E_-)$$

$$E_{\pm} = E \pm \sqrt{E^2 - 1}$$

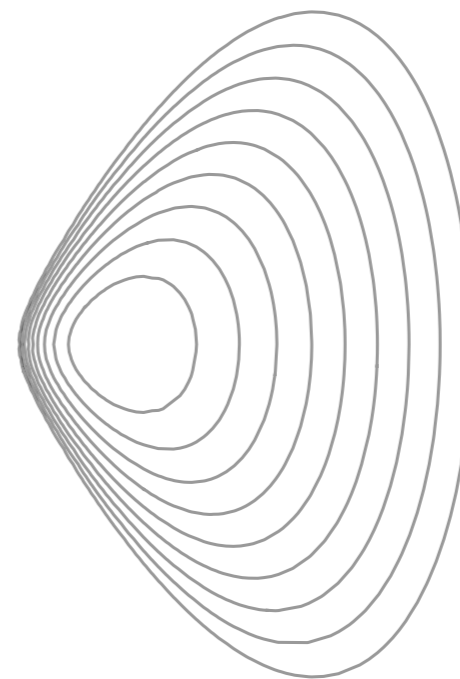

The trajectories all go through the origin.

Two Problems

- The trajectories are **indistinguishable** as they pass through the origin.
- The phase space is no longer compact; Liouville's theorem* does not necessarily hold.
- These properties are shared by many nonlinear mathematical models.

* Liouville's thm gives the solution by quadratures.

Elliptic Functions

- Doubly-periodic, meromorphic functions

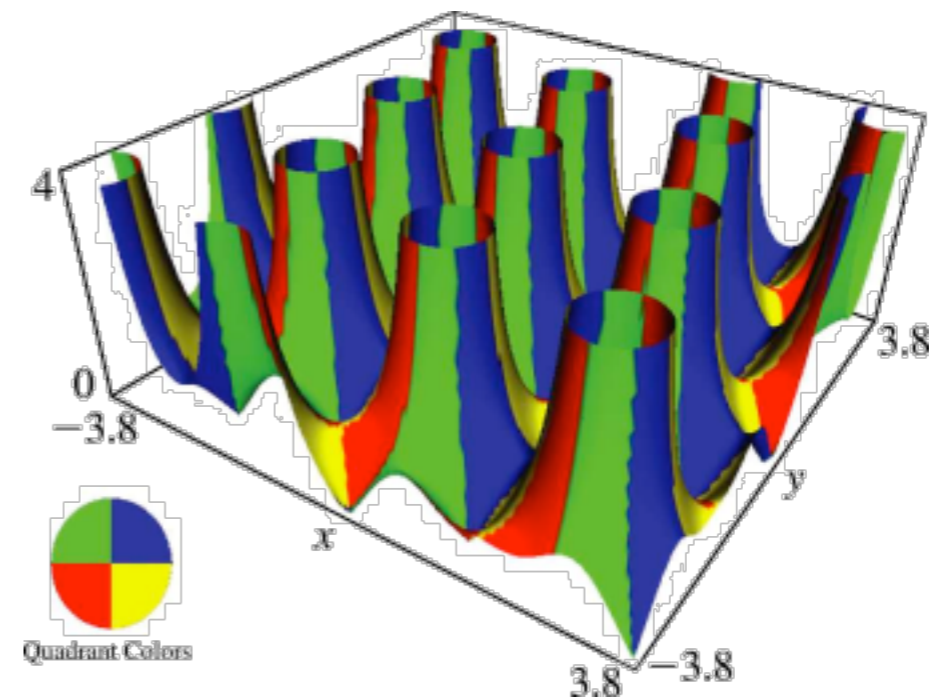
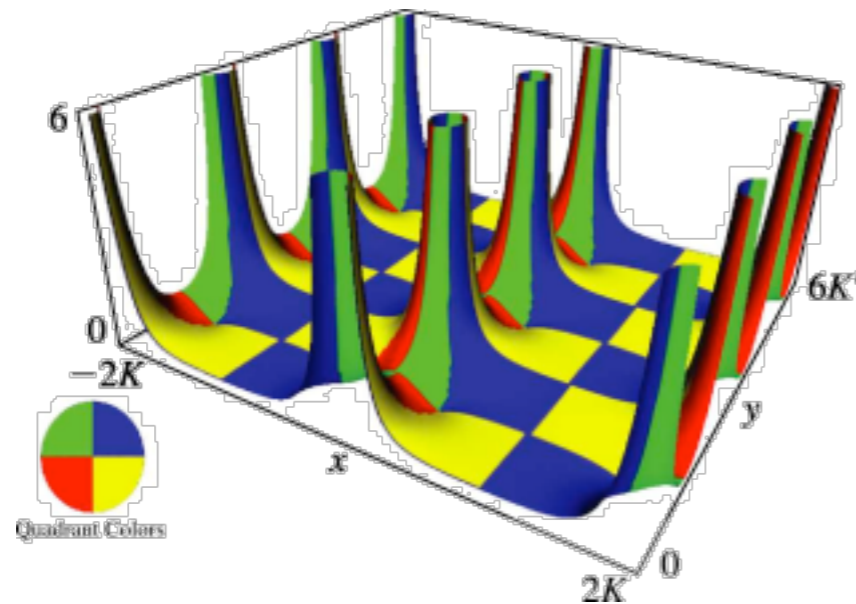

Elliptic Functions in phase space

$$\begin{aligned} & \ddot{w} = 6w^2 - \frac{g_2}{2} \\ \Rightarrow & \frac{\dot{w}^2}{2} = 2w^3 - \frac{g_2}{2}w - \frac{g_3}{2} \\ \Rightarrow & w(t) = \wp(t - t_0; g_2, g_3) \end{aligned}$$

The phase space coordinatised by (w, \dot{w}) is **not** compact, due to poles.

Elliptic Functions parametrize curves

- In phase space, $\dot{w} = y$, $w = x$, the conserved quantity becomes

$$y^2 = 4x^3 - g_2x - g_3$$

- Initial values determine g_3
- Each value of g_3 defines a level curve of

$$f(x, y) = y^2 - 4x^3 + g_2x$$

Cubic Pencil

A Weierstrass cubic pencil:

$$y^2 - 4x^3 + g_2x + g_3 = 0, \quad g_2 = 2, g_3 = -E$$

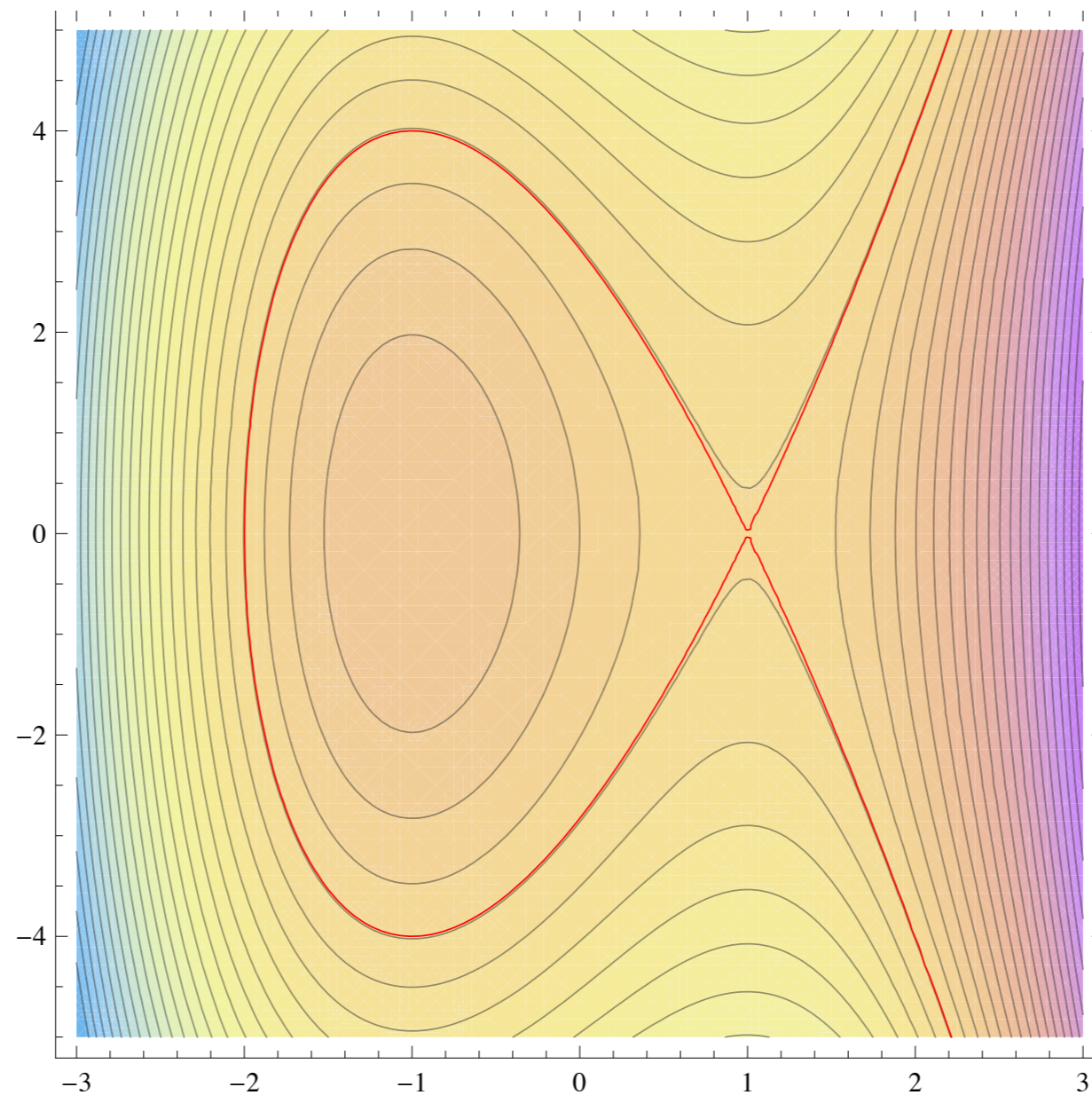

Motivation

- Korteweg-de Vries equation

$$w_\tau + 6 w w_\xi + w_{\xi\xi\xi} = 0$$

$$\begin{cases} w = -2 y(x) - 2 \tau \\ x = \xi + 6 \tau^2 \end{cases}$$

$$\Rightarrow \begin{cases} w_\tau &= -24 \tau y_x - 2 \\ w_\xi &= -2 y_x \\ w_{\xi\xi\xi} &= -2 y_{xxx} \end{cases}$$

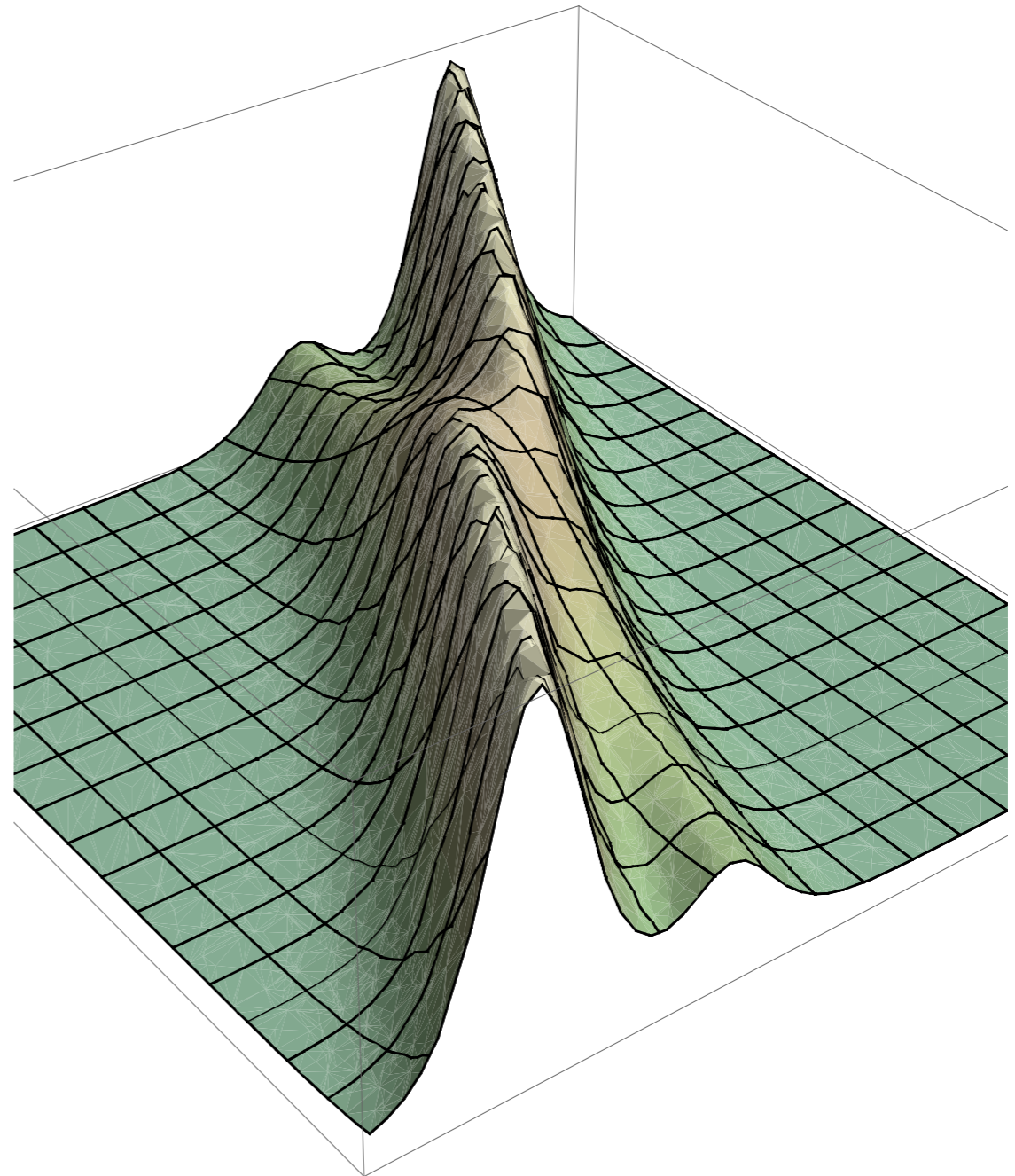

Motivation

- Korteweg-de Vries equation

$$w_\tau + 6 w w_\xi + w_{\xi\xi\xi} = 0$$

$$\begin{cases} w = -2y(x) - 2\tau \\ x = \xi + 6\tau^2 \end{cases}$$

$$\Rightarrow \begin{cases} w_\tau = -24\tau y_x - 2 \\ w_\xi = -2y_x \\ w_{\xi\xi\xi} = -2y_{xxx} \end{cases}$$

 The first Painlevé equation
$$y'' = 6y^2 - x$$

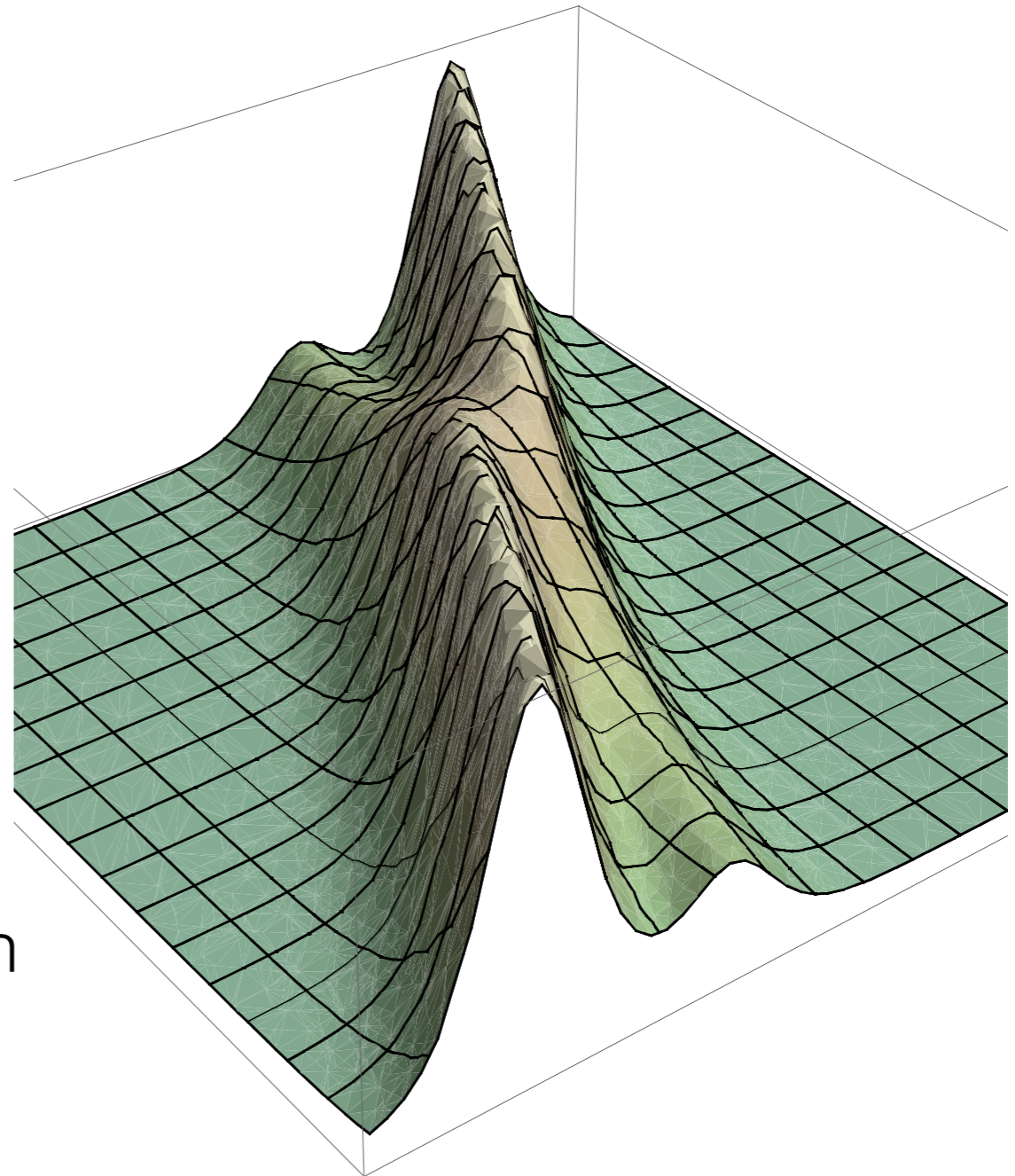

Applications

- Electrical structures of interfaces in steady electrolysis *L. Bass, Trans Faraday Soc 60 (1964) 1656–1663*
- Spin-spin correlation functions for the 2D Ising model *TT Wu, BM McCoy, CA Tracy, E Barouch Phys Rev B13 (1976) 316–374*
- Spherical electric probe in a continuum gas *PCT de Boer, GSS Ludford, Plasma Phys 17 (1975) 29–41*
- Cylindrical Waves in General Relativity *S Chandrashekar, Proc. R. Soc. Lond. A 408 (1986) 209–232*
- Non-perturbative 2D quantum gravity *Gross & Migdal PRL 64(1990) 127-130*
- Orthogonal polynomials with non-classical weight function *AP Magnus J. Comput Appl. Anal. 57 (1995) 215–237*
- Level spacing distributions and the Airy kernel *CA Tracy, H Widom CMP 159 (1994) 151–174*
- Spatially dependent ecological models: *J & Morrison Anal Appl 6 (2008) 371-381*
- Gradient catastrophe in fluids: *Dubrovin, Grava & Klein J. Nonlin. Sci 19 (2009) 57-94*

What do we know about the solutions of these equations?



Real Solutions

Consider $P_1 \quad w_{tt} = 6w^2 - t$ for $w(t), t \in \mathbb{R}$

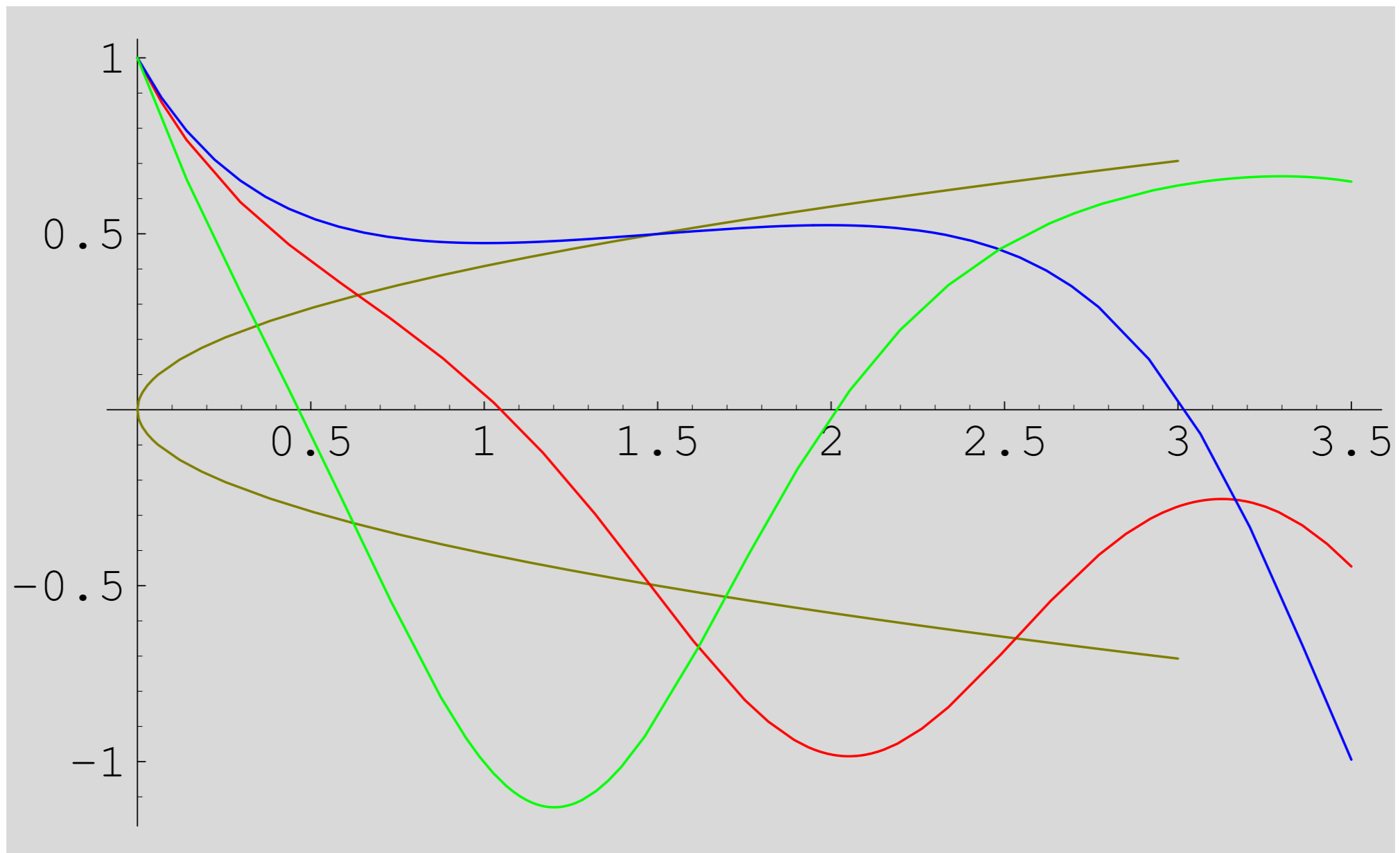

$$u(0) = 0, \quad u'(0) = 0$$

Complex Solutions

- Movable poles
- Transcendentality of general solutions
- Special solutions
- Asymptotic behaviours

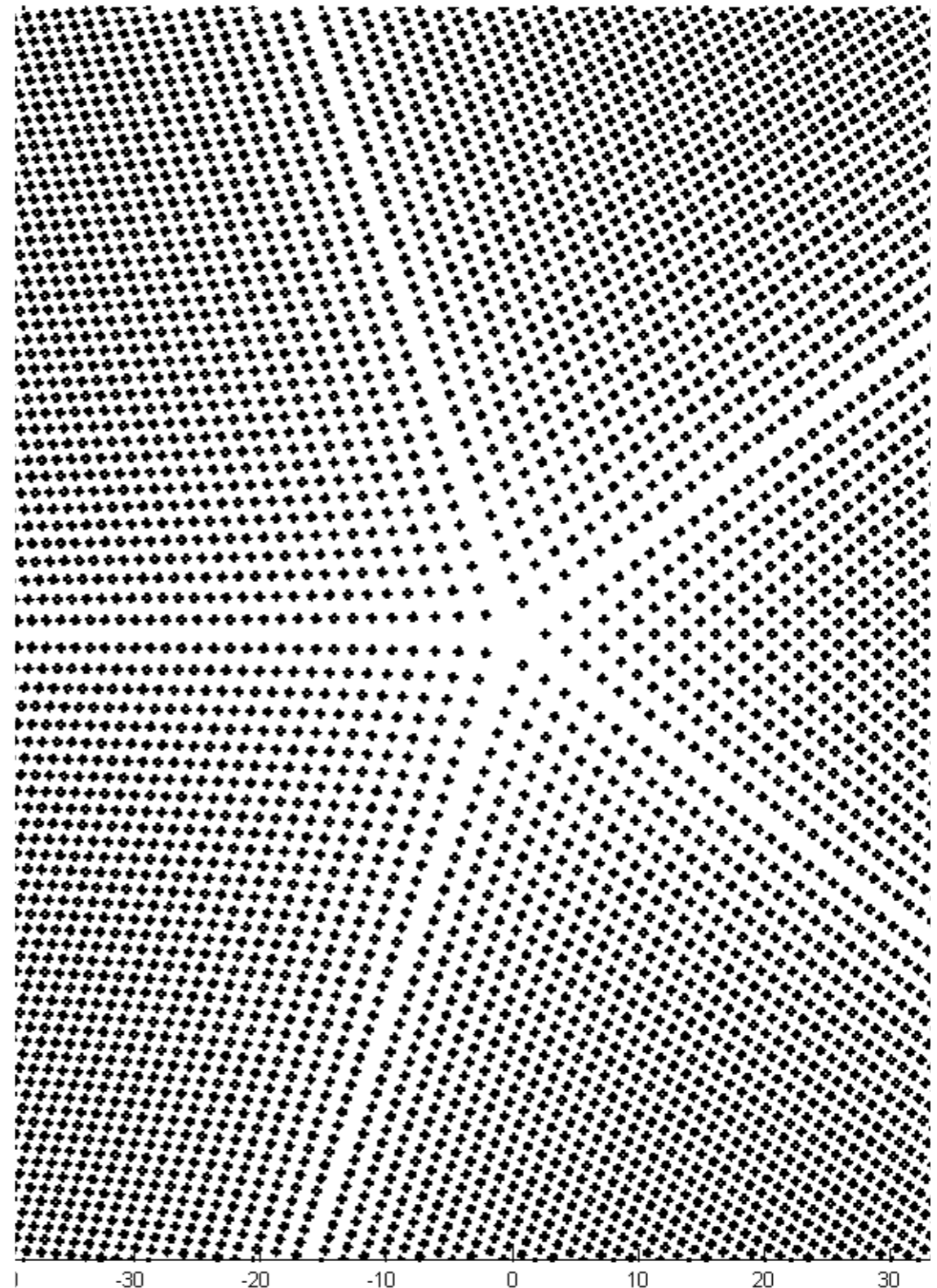

Fornberg & Weideman 2009

P_I

General Solutions

- P_I: $w_{tt} = 6w^2 - t$
- in system form

$$\frac{d}{dt} \begin{pmatrix} w_1 \\ w_2 \end{pmatrix} = \begin{pmatrix} w_2 \\ 6w_1^2 - t \end{pmatrix}$$

- has t-dependent Hamiltonian

$$H = \frac{w_2^2}{2} - 2w_1^3 + tw_1$$

Perturbed Form

- Or, in Boutroux's coordinates:

$$w_1 = t^{1/2} u_1(z), \quad w_2 = t^{3/4} u_2(z), \quad z = \frac{4}{5} t^{5/4}$$

$$\begin{pmatrix} \dot{u}_1 \\ \dot{u}_2 \end{pmatrix} = \begin{pmatrix} u_2 \\ 6u_1^2 - 1 \end{pmatrix} - \frac{1}{5z} \begin{pmatrix} 2u_1 \\ 3u_2 \end{pmatrix}$$

- a perturbation of an elliptic curve as $|z| \rightarrow \infty$

$$E = \frac{u_2^2}{2} - 2u_1^3 + u_1 \quad \Rightarrow \quad \frac{dE}{dz} = \frac{1}{5z} (6E + 4u_1)$$

Perturbed Form

- Or, in Boutroux's coordinates:

$$w_1 = t^{1/2} u_1(z), \quad w_2 = t^{3/4} u_2(z), \quad z = \frac{4}{5} t^{5/4}$$

$$\begin{pmatrix} \dot{u}_1 \\ \dot{u}_2 \end{pmatrix} = \begin{pmatrix} u_2 \\ 6u_1^2 - 1 \end{pmatrix} - \frac{1}{5z} \begin{pmatrix} 2u_1 \\ 3u_2 \end{pmatrix}$$

- a perturbation of an elliptic curve as $|z| \rightarrow \infty$

$$E = \frac{u_2^2}{2} - 2u_1^3 + u_1 \quad \Rightarrow \quad \frac{dE}{dz} = \frac{1}{5z} (6E + 4u_1)$$

Similarly

- P_{II}: $w_{tt} = 2w^3 + tw + \alpha$
- P_{IV}: $w_{tt} = \frac{w_t^2}{2w} + \frac{3w^3}{2} + 4tw^2$
 $+ 2(t^2 - 1 + \alpha_1 + 2\alpha_2)w - \frac{2\alpha_1^2}{w}$

have system forms that are perturbations of autonomous systems in the limit $|t| \rightarrow \infty$

Projective Space

- What if x, y become unbounded?

- Use projective geometry: $x = \frac{u}{w}, y = \frac{v}{w}$

$$[x, y, 1] = [u, v, w] \in \mathbb{CP}^2$$

- The level curves of P_I are now

$$F_I = wv^2 - 4u^3 + g_2uw^2 + g_3w^3$$

all intersecting at the **base point** $[0, 1, 0]$.

\Rightarrow To describe solutions, **resolve** the flow through this point

Resolving a base pt

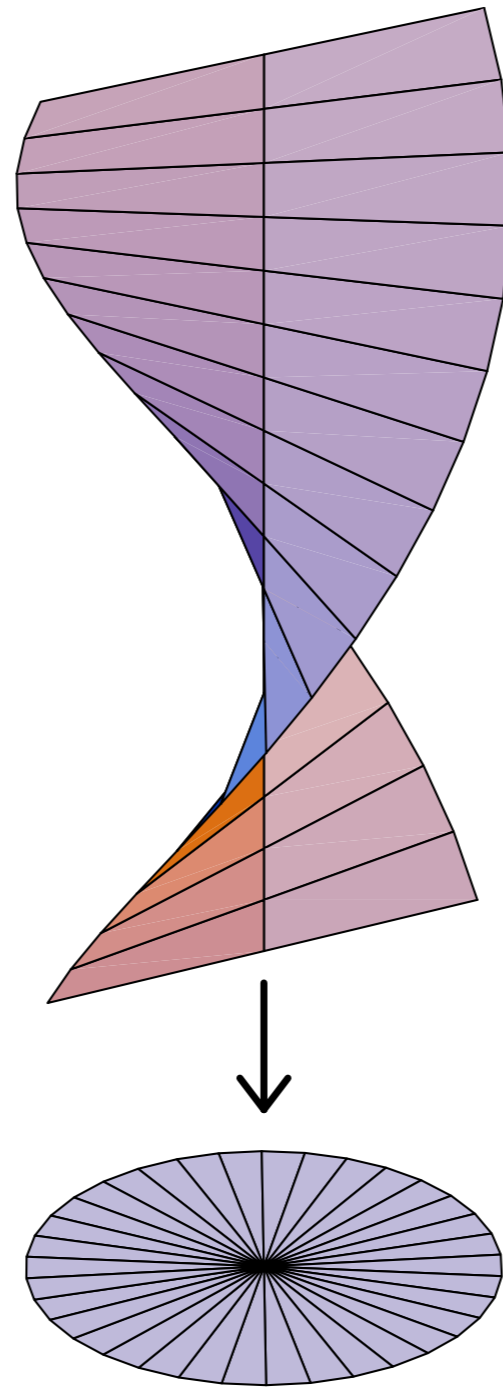

Resolution

- “Blow up” the singularity or base point:

$$f(x, y) = y^2 - x^3$$

$$(x, y) = (x_1, x_1 y_1)$$

$$\Rightarrow x_1^2 y_1^2 - x_1^3 = 0$$

$$\Leftrightarrow x_1^2 (y_1^2 - x_1) = 0$$

- Note that

$$x_1 = x, y_1 = y/x$$

$$y^2 = x^3$$

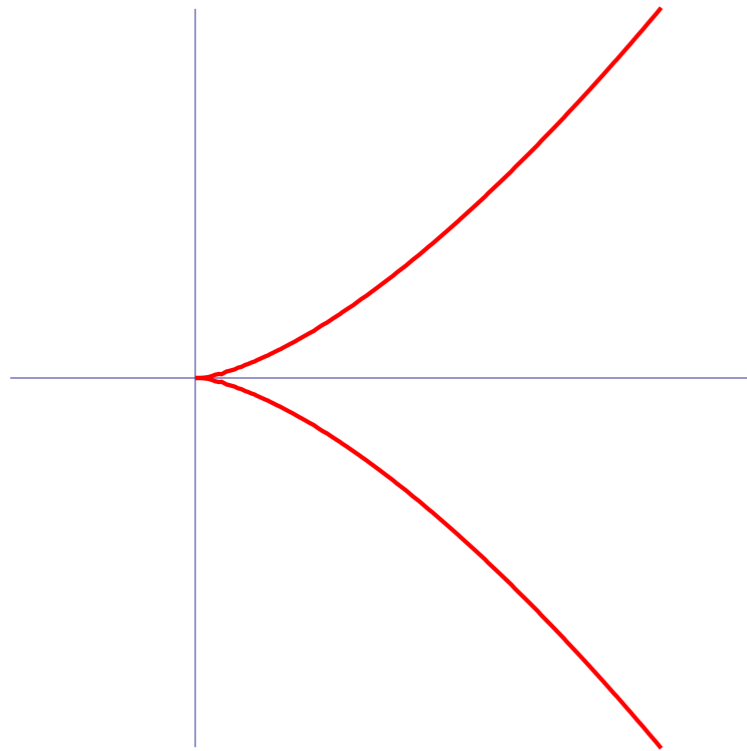

Method

$$f(x, y) = y^2 - x^3$$

$$(x, y) = (x_1, x_1 y_1)$$

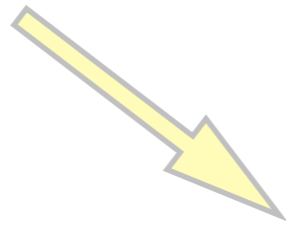

$$f(x_1, x_1 y_1) = x_1^2 (y_1^2 - x_1)$$

$$L_1 : (-1)$$

$$y_1^2 = x_1$$

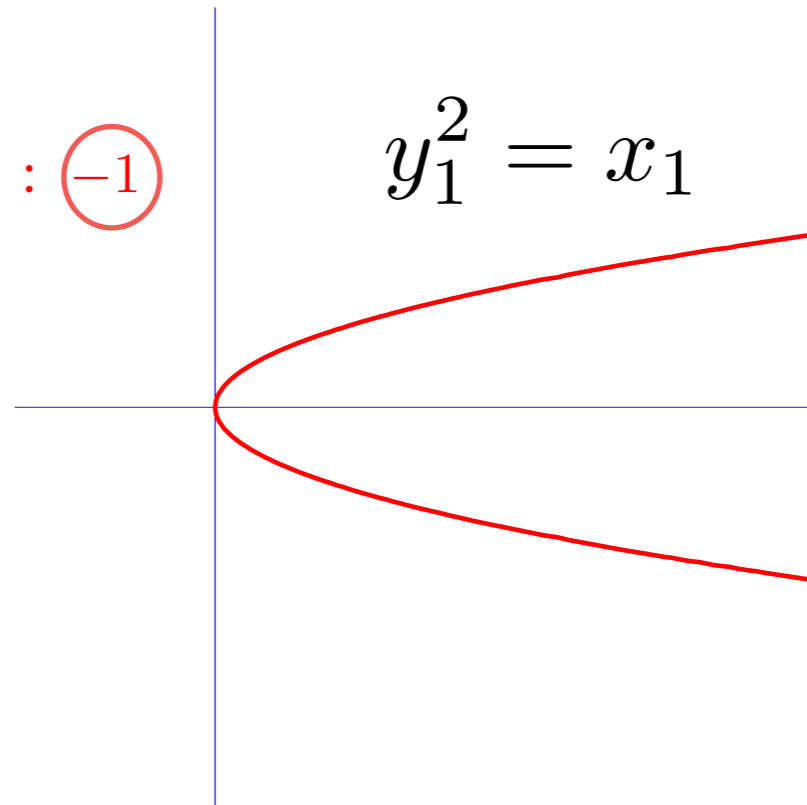

$$f_1(x_1, y_1) = y_1^2 - x_1$$

$$f_1(x_2, y_2, y_2) = y_2(y_2 - x_2)$$

$$(x_1, y_1) = (x_2, y_2, y_2)$$

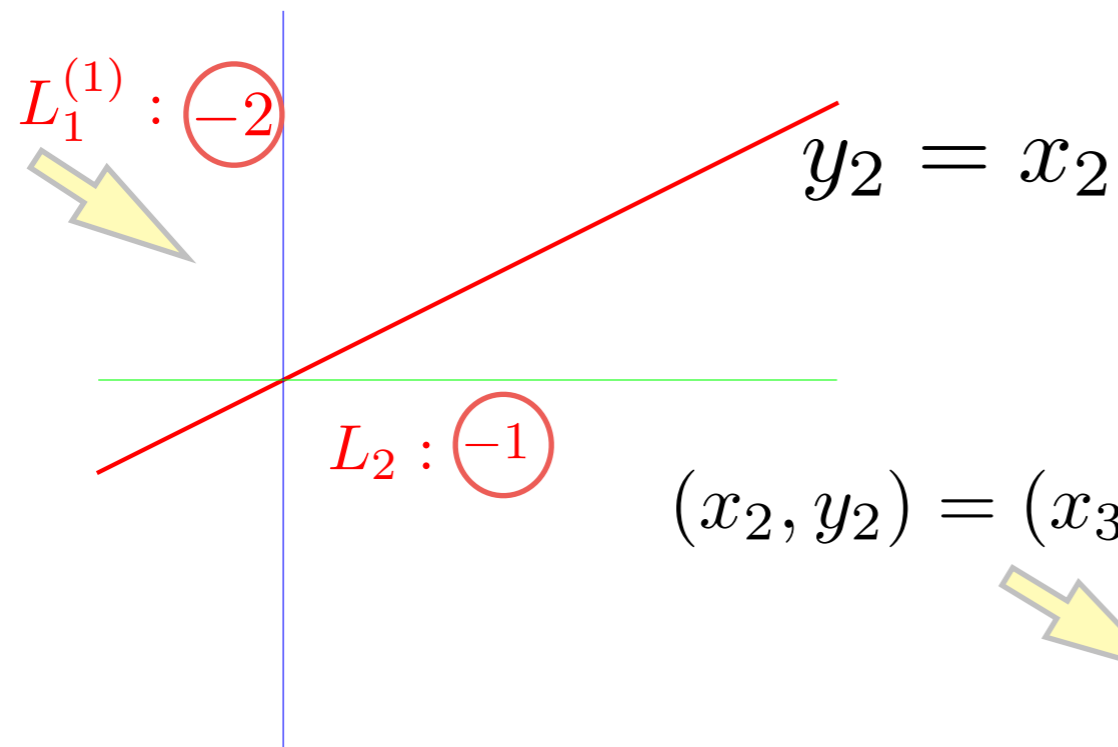

$$(x_2, y_2) = (x_3, x_3 y_3)$$

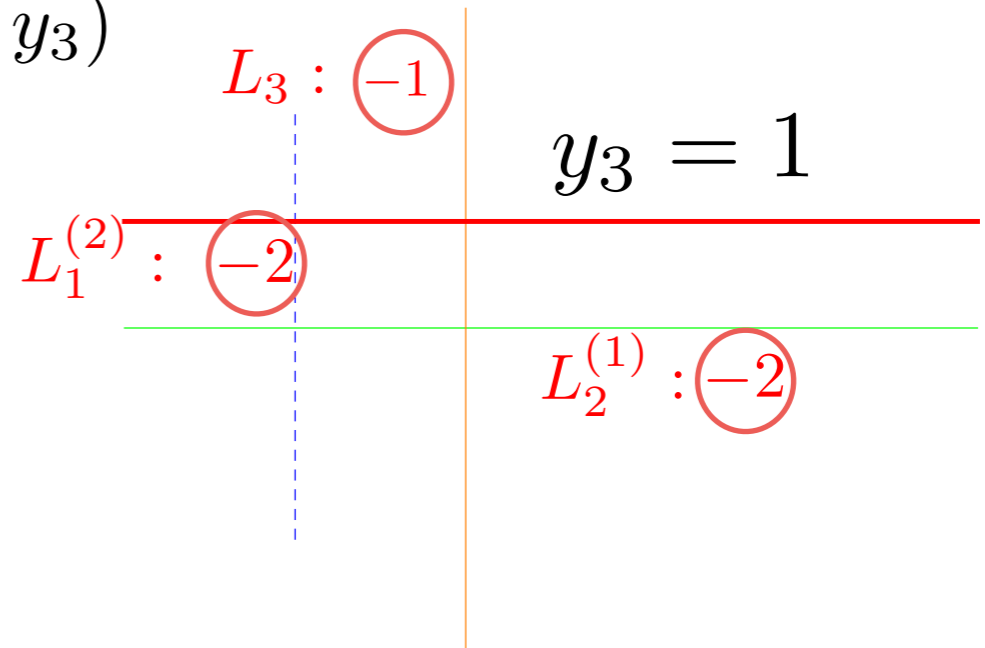

$$f_2(x_2, y_2) = y_2 - x_2$$

$$f_2(x_3, x_3 y_3) = x_3(y_3 - 1)$$

Initial-Value Space

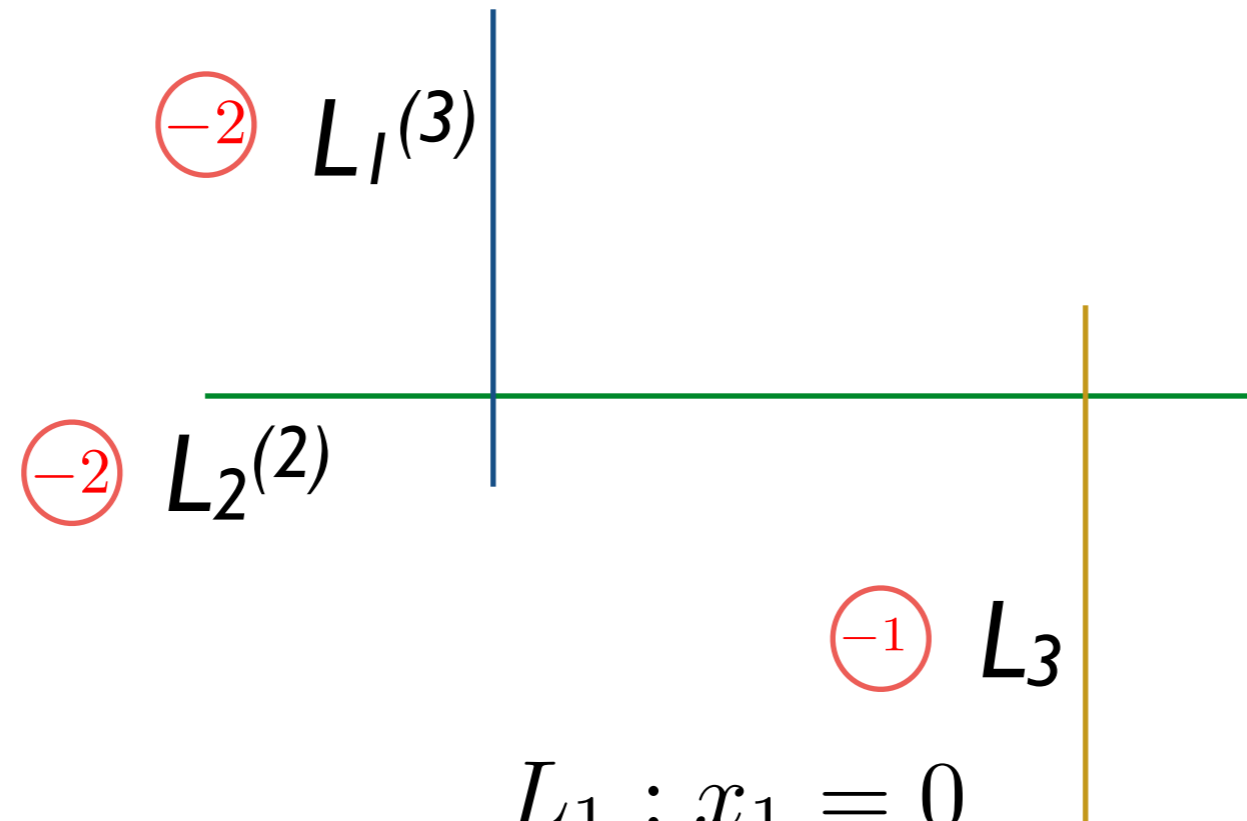

$$L_1 : x_1 = 0$$

$$L_2 : y_2 = 0$$

$$L_3 : x_3 = 0$$

Now the space is compactified and regularised.

Initial-Value Space

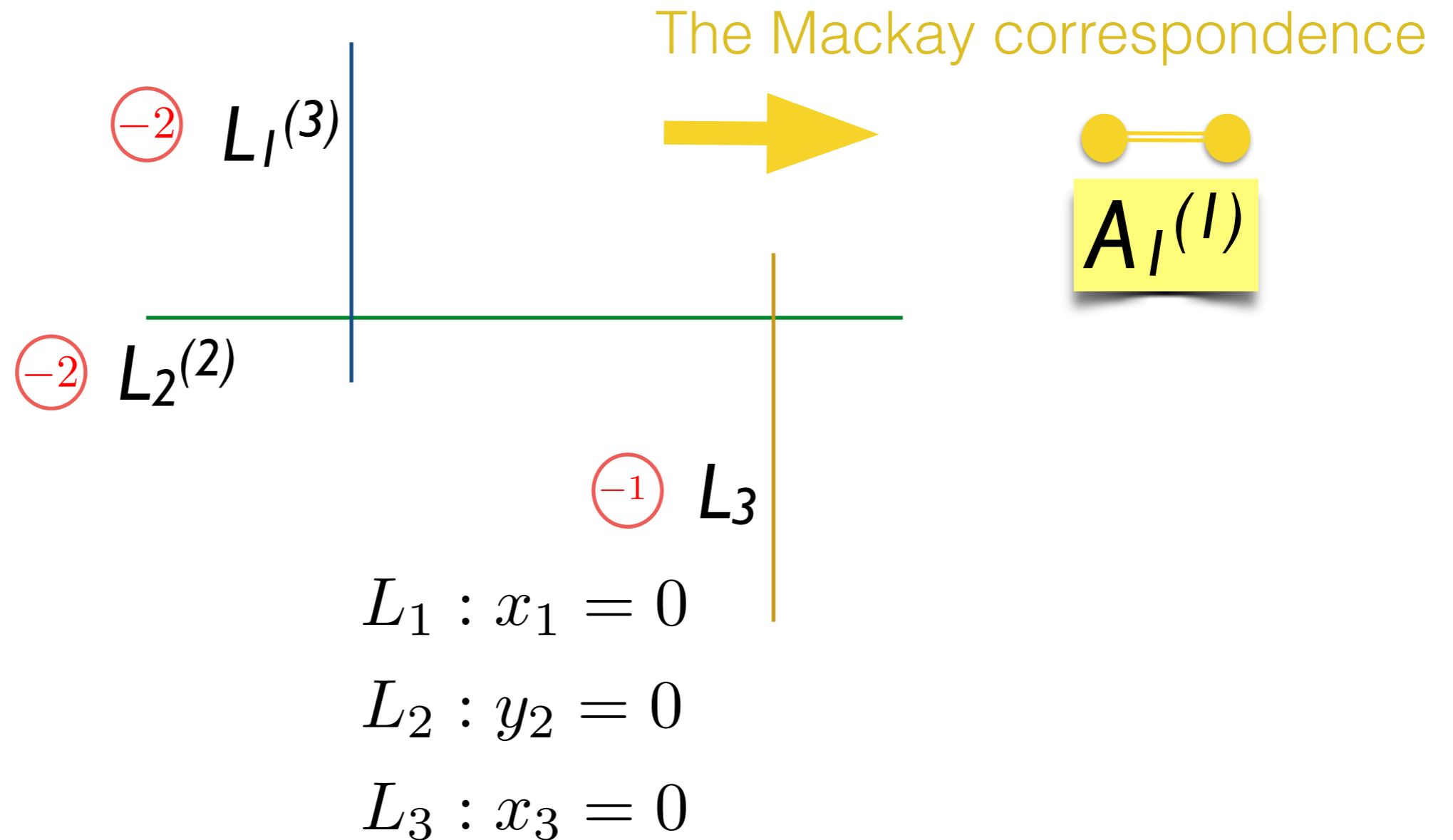

Now the space is compactified and regularised.

Good Resolution

- When all curves intersect each other transversally at distinct points, the result is called a “good resolution”.
- Hironaka’s theorem guarantees this in complex projective space.
- Note: each transformation had the form

$$x_1 = x, y_1 = y/x$$

Unifying Property

The space of initial values of a Painlevé system is resolved by “blowing up” 9 points in $\mathbb{C}P^2$ (or 8 points in $\mathbb{P}^1 \times \mathbb{P}^1$)

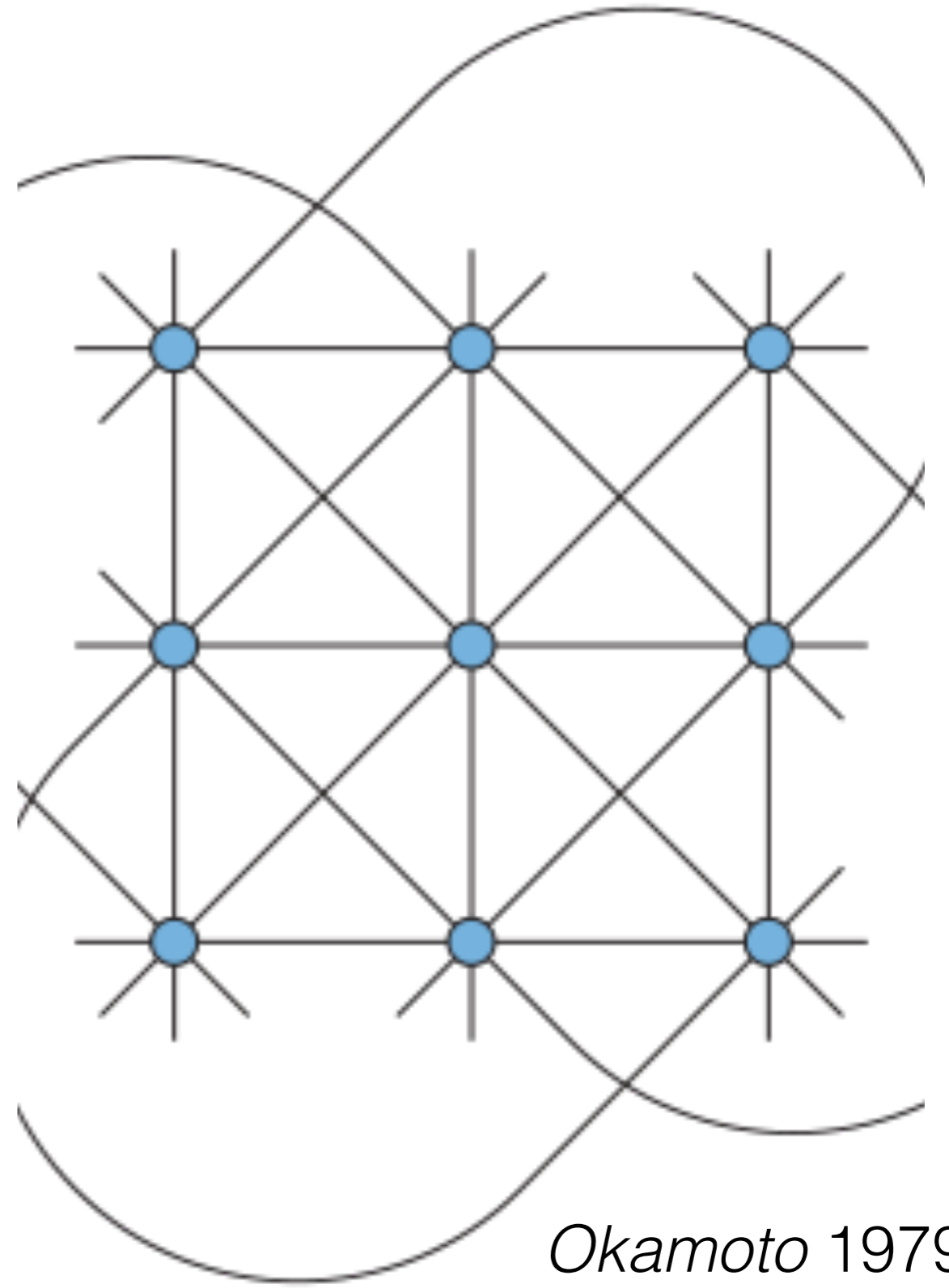

Okamoto 1979

Sakai 2001

Initial-Value Space of P_1

- There are nine base points:

$$b_0 : u_{031} = 0, u_{032} = 0$$

$$b_1 : u_{111} = 0, u_{112} = 0$$

$$b_2 : u_{211} = 0, u_{212} = 0$$

$$b_3 : u_{311} = 4, u_{312} = 0$$

$$b_4 : u_{411} = 4, u_{412} = 0$$

$$b_5 : u_{511} = 0, u_{512} = 0$$

$$b_6 : u_{611} = 0, u_{612} = 0$$

$$b_7 : u_{711} = 32, u_{712} = 0$$

$$b_8 : u_{811} = -\frac{2^8}{(5z)}, u_{812} = 0$$

- Only the last one differs from the elliptic case.

P_1

L_9

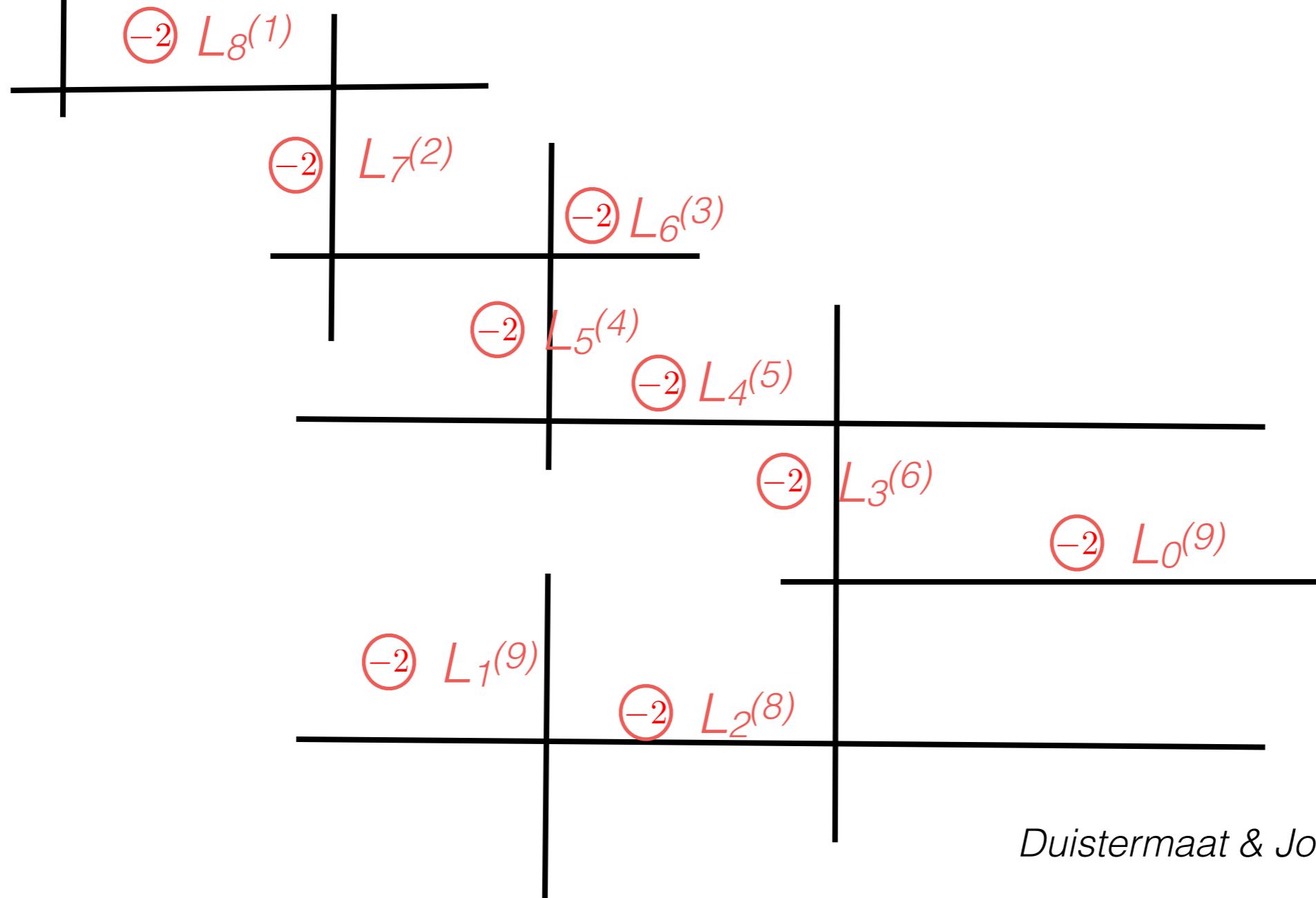

P_1

L_9

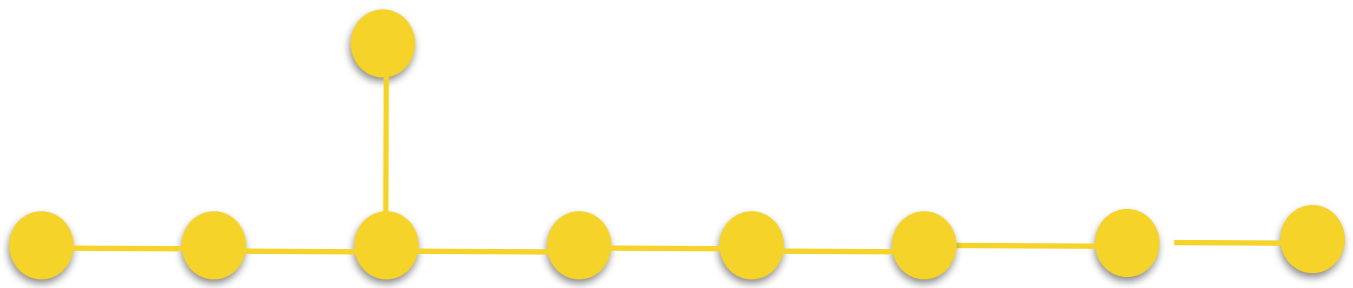
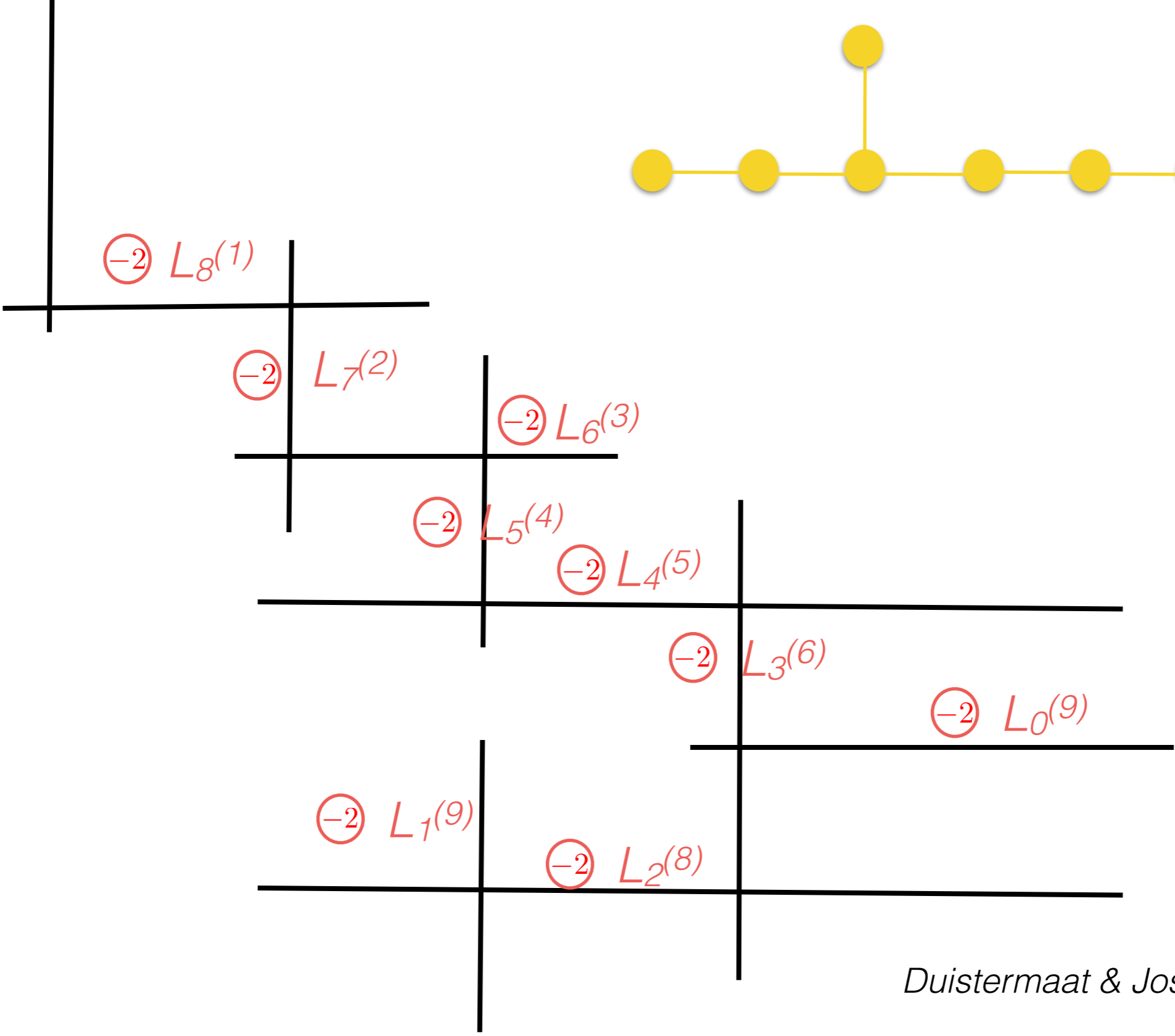

P_1

L_9

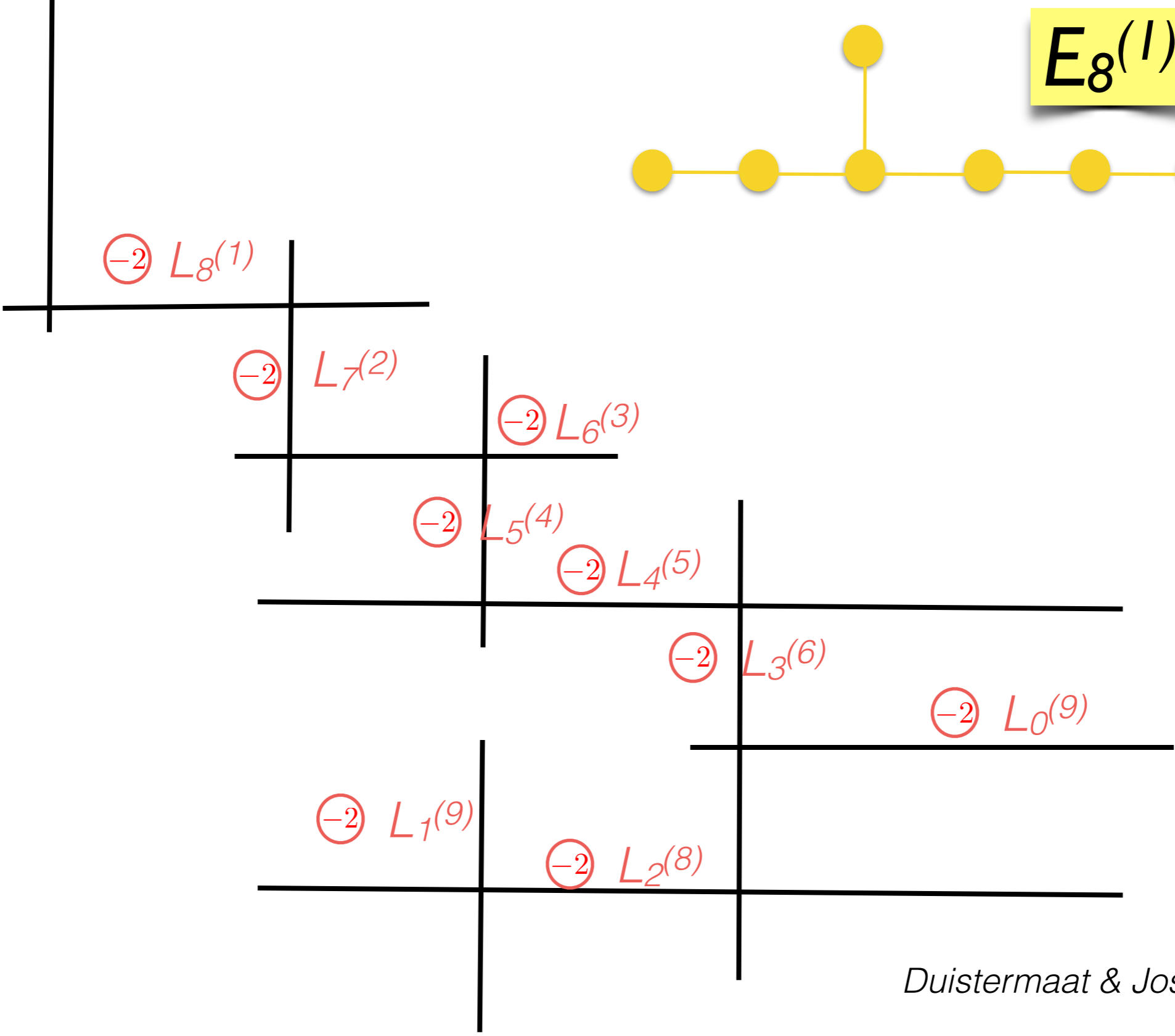

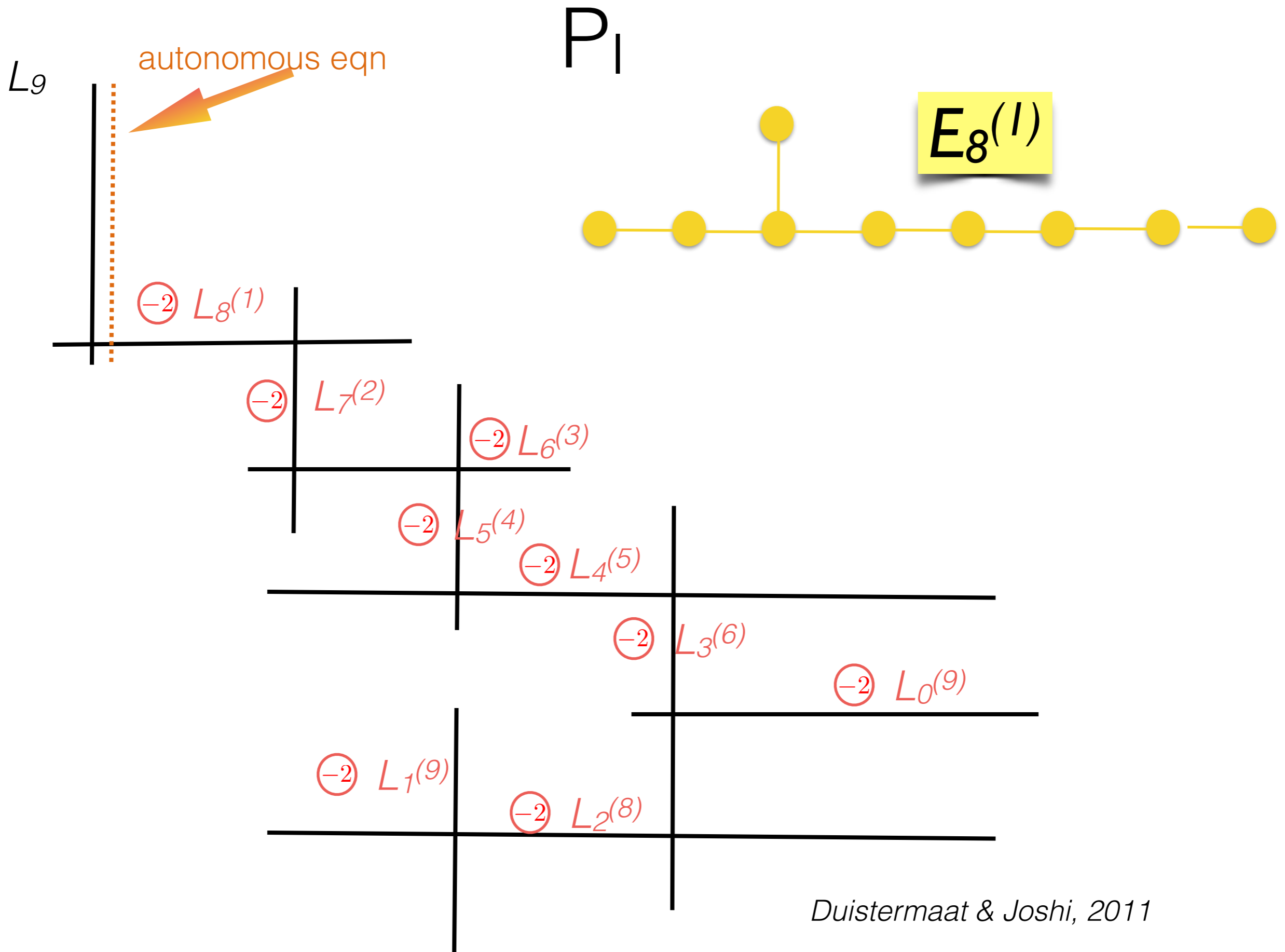

P_{II}

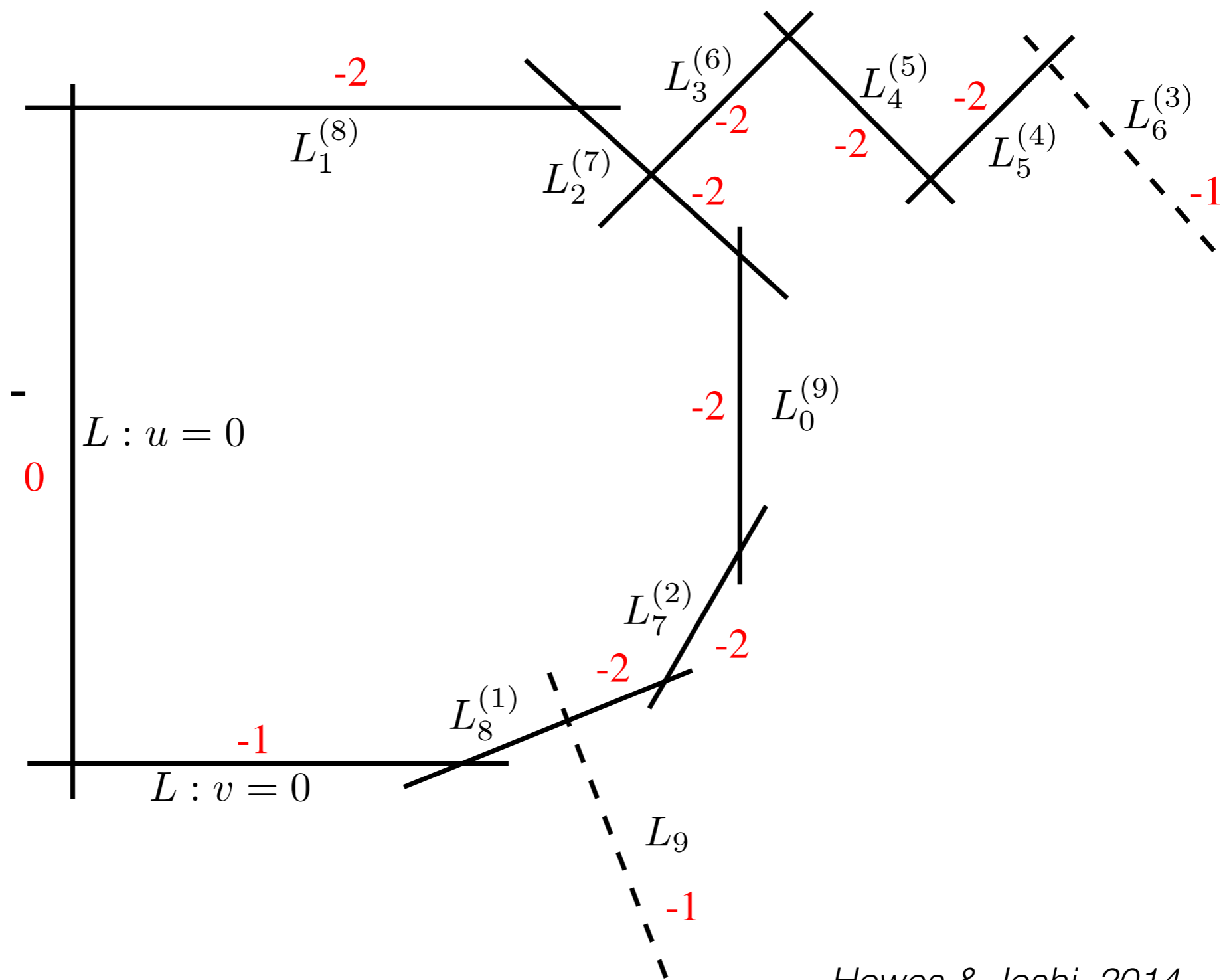

P_{II}

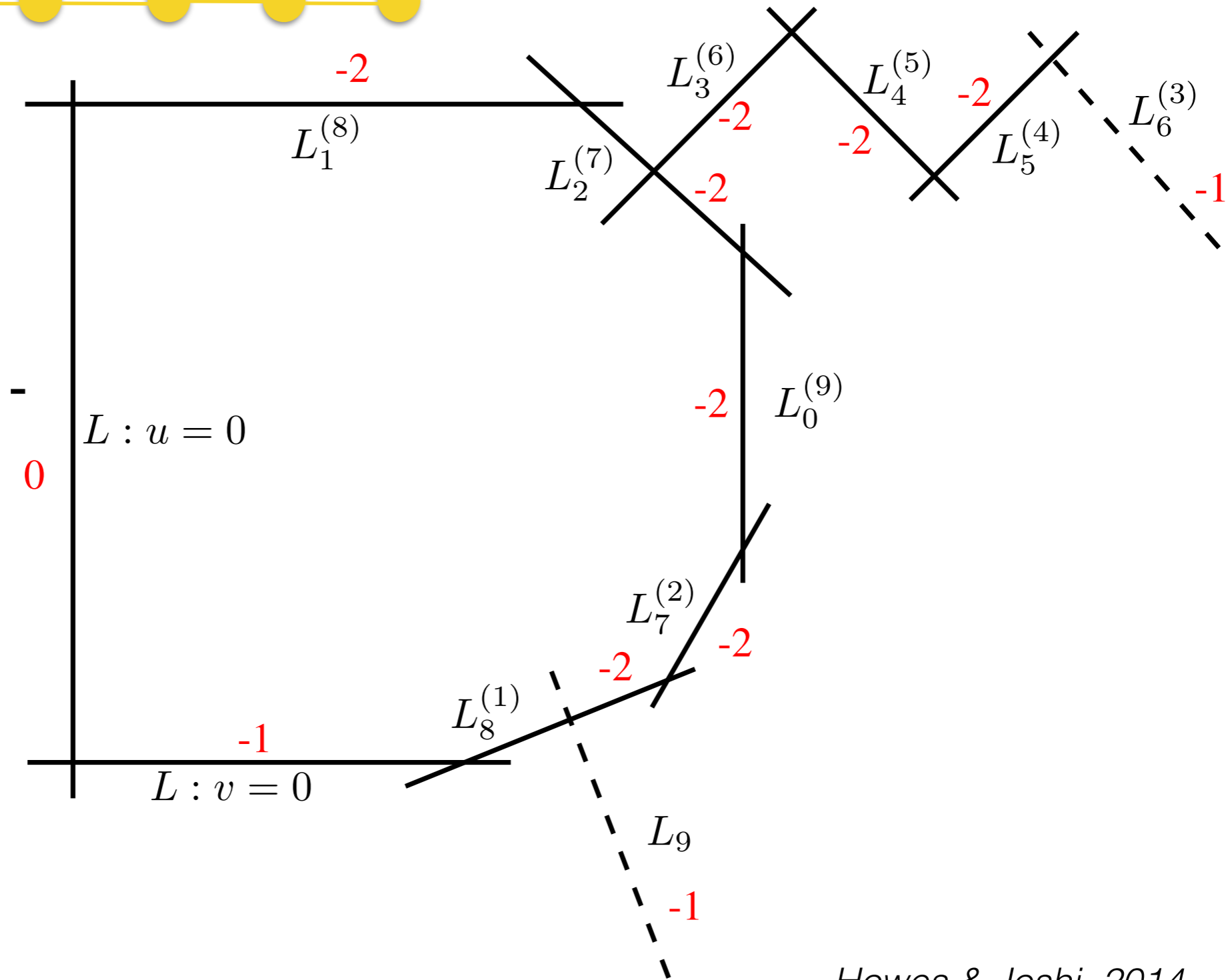
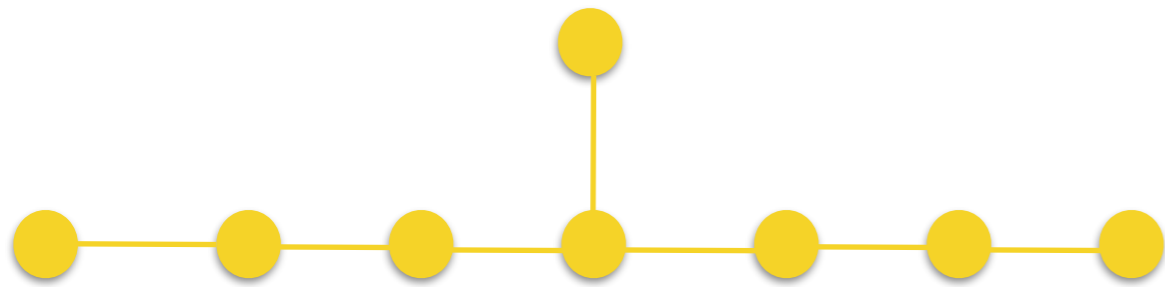

P_{II}

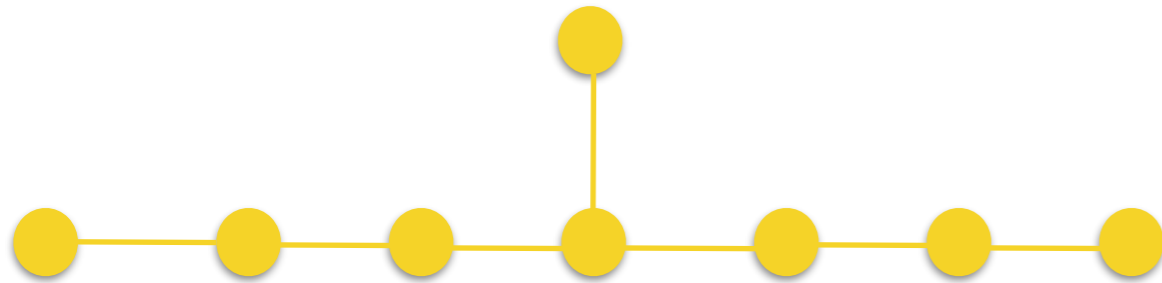

$E_7^{(I)}$

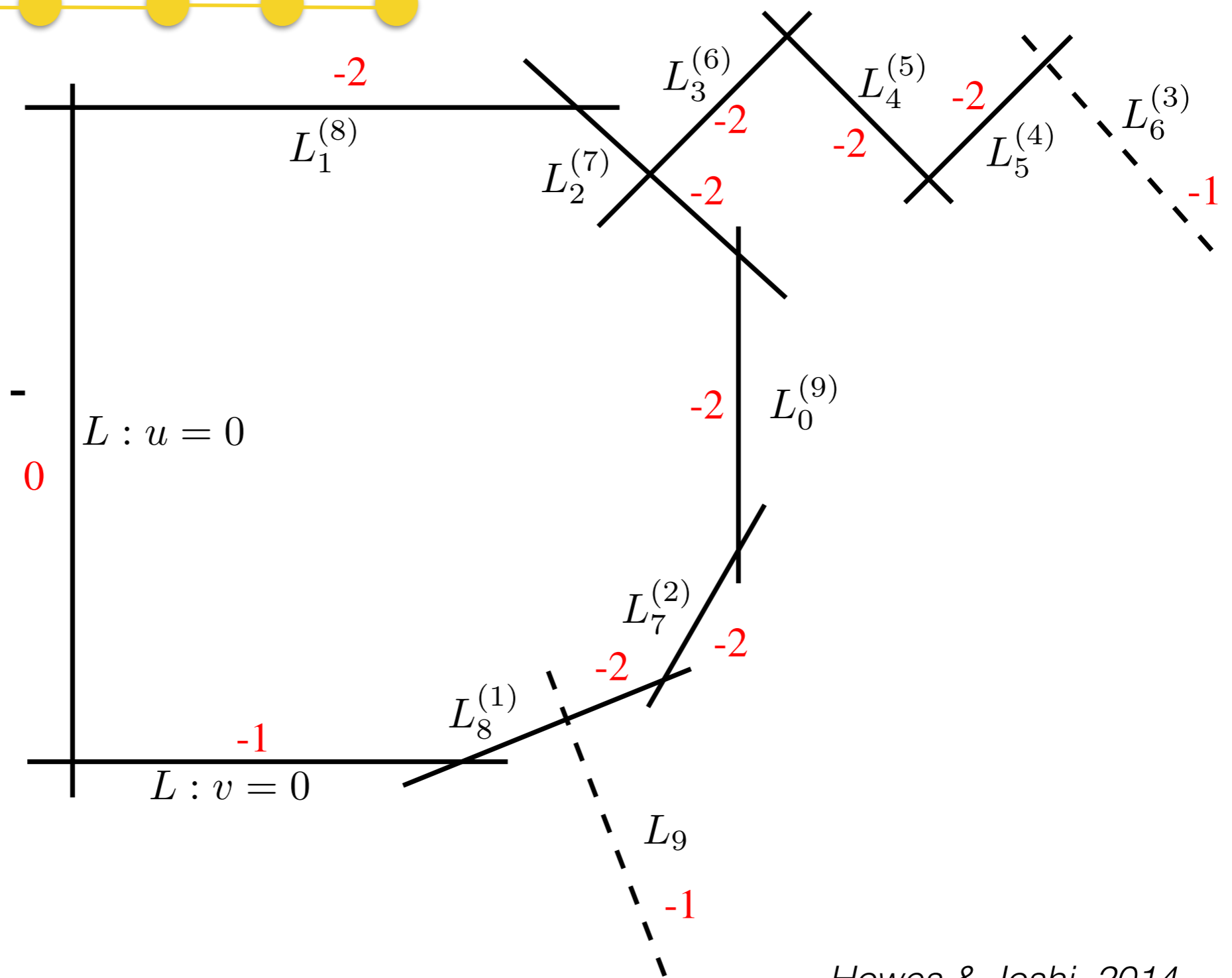

P_{II}

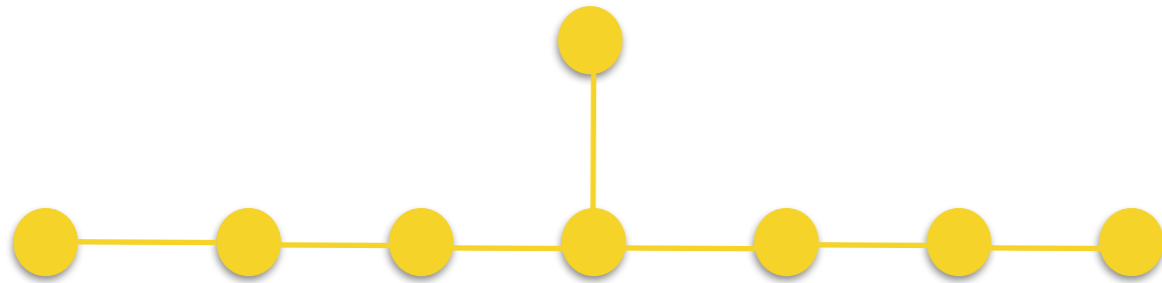

$E_7^{(1)}$

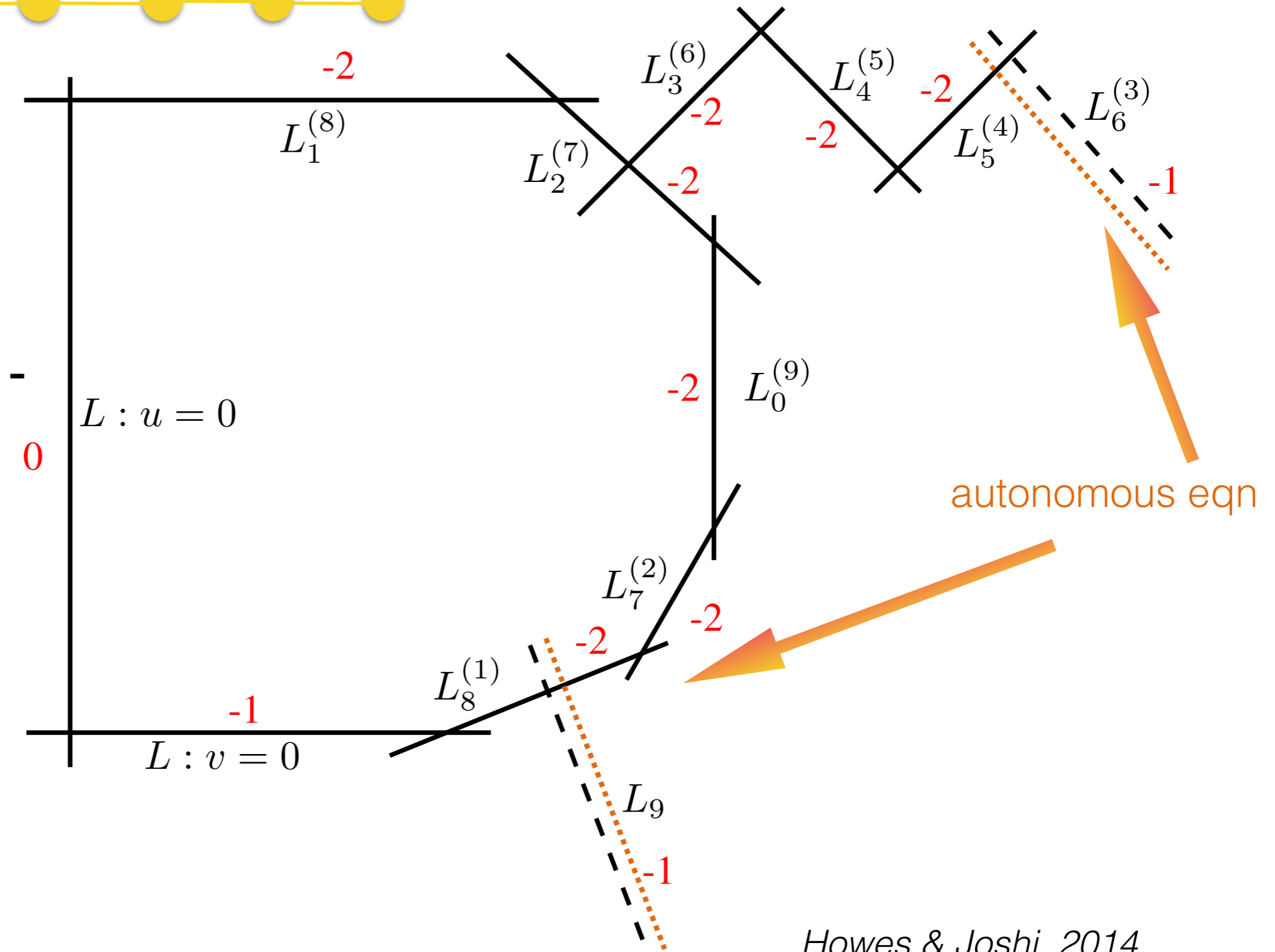

P_{IV}

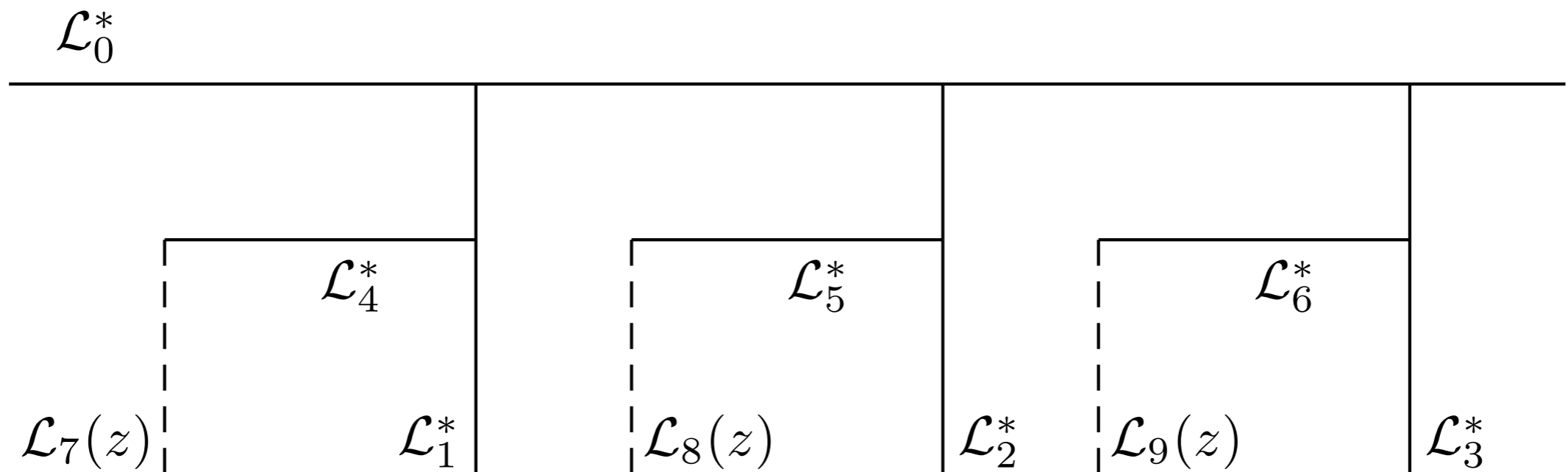

P_{IV}

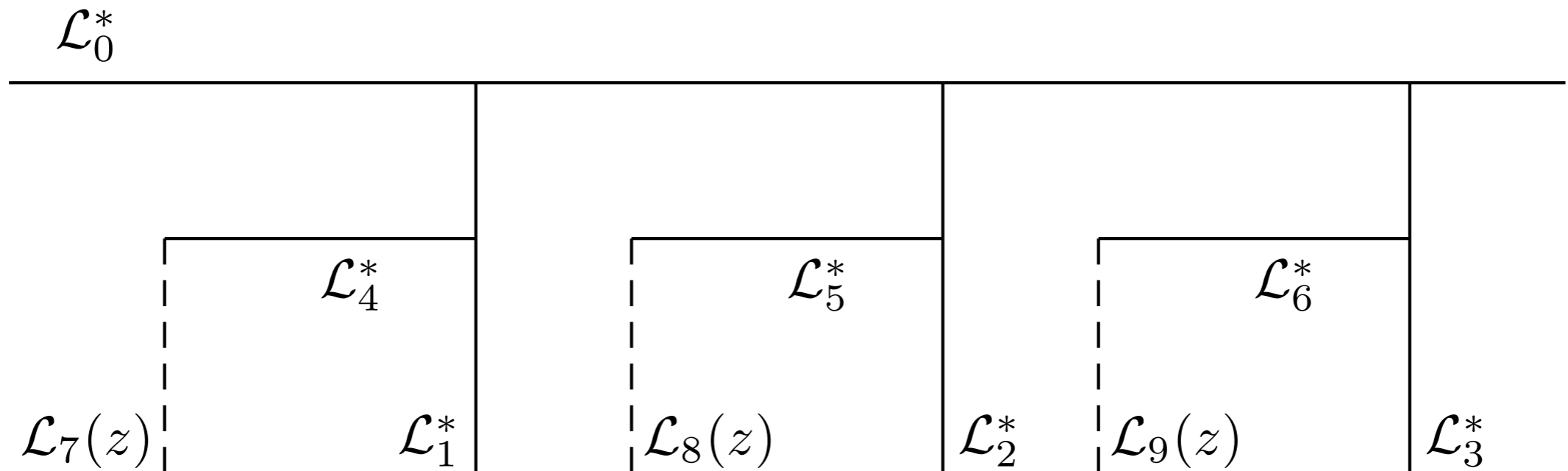
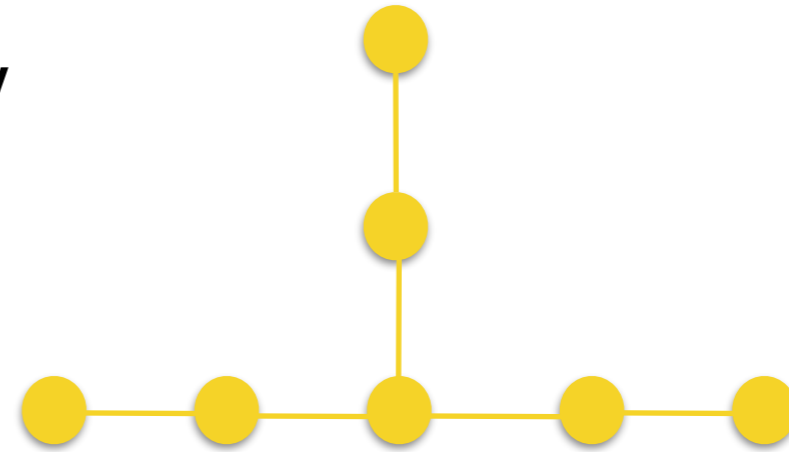

P_{IV}

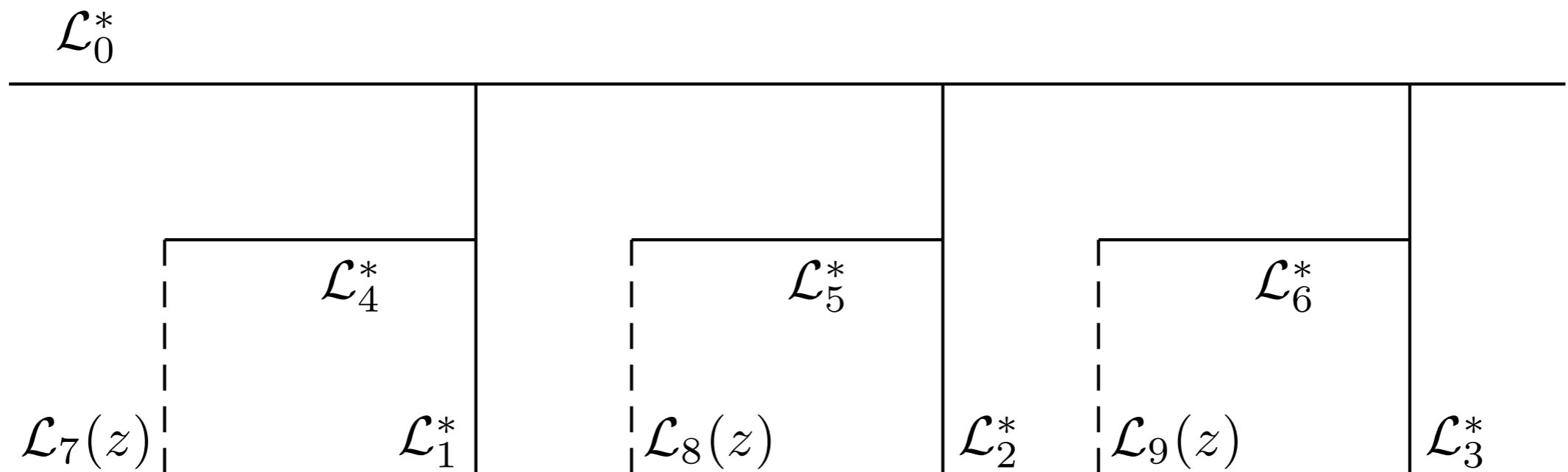
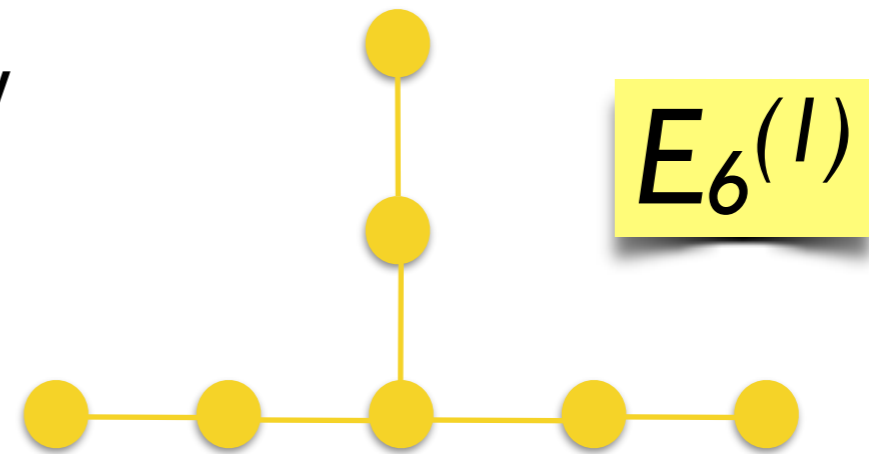

P_{IV}

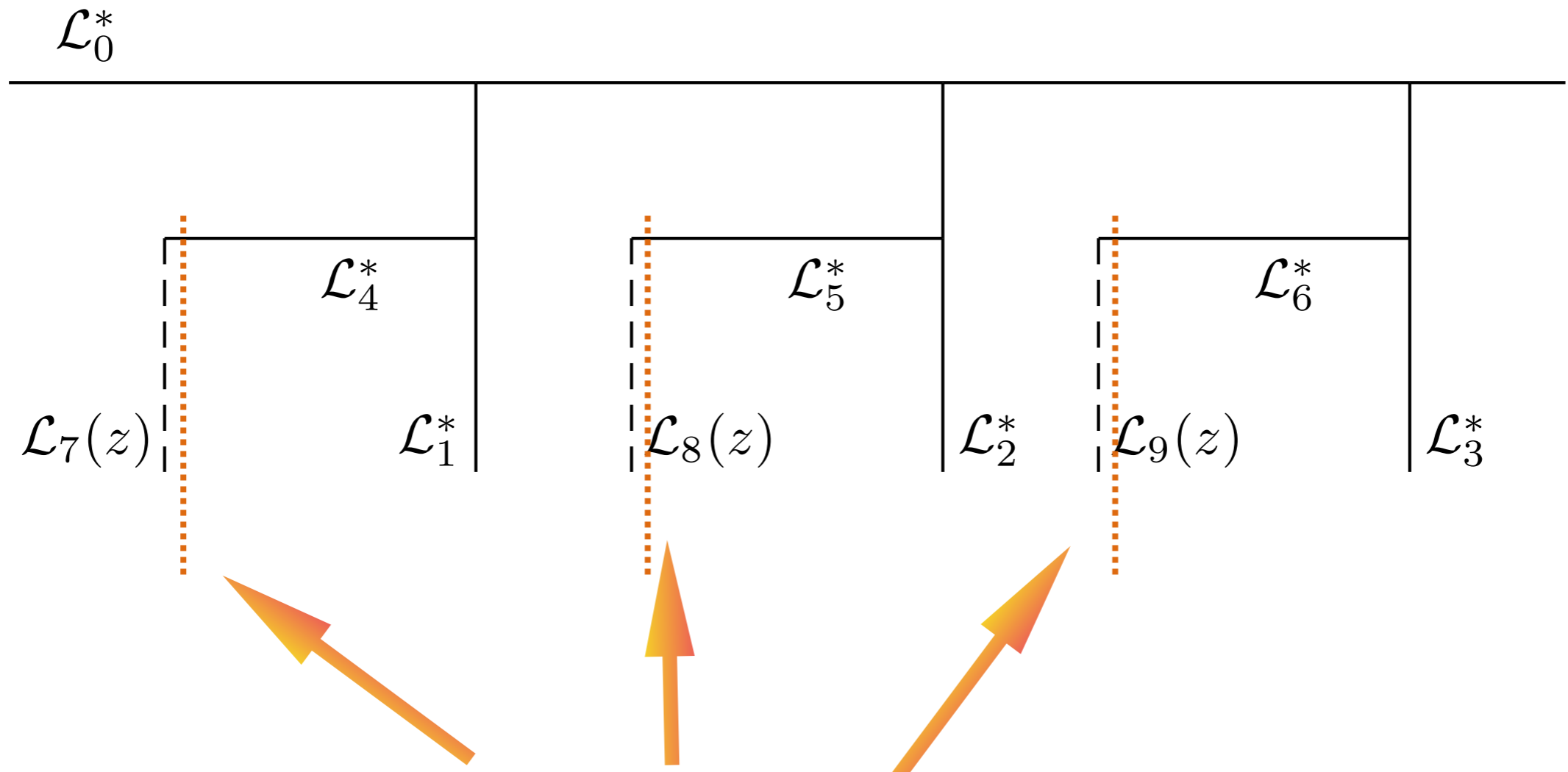
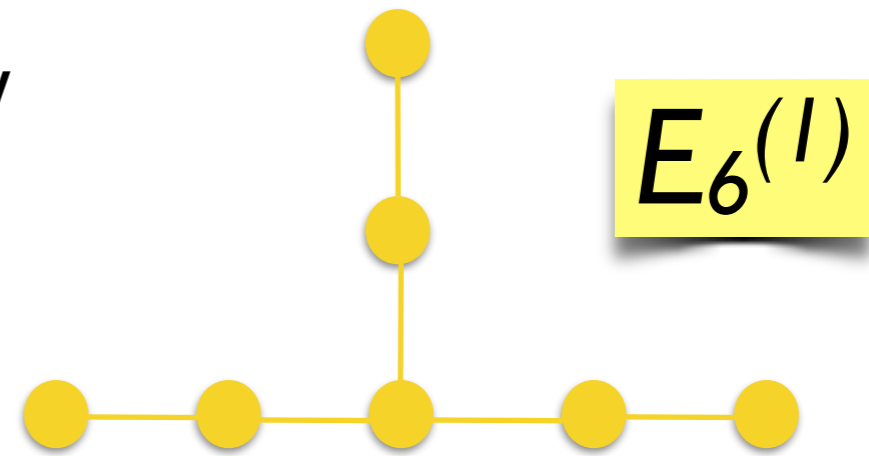

autonomous eqn

Sakai's Description I

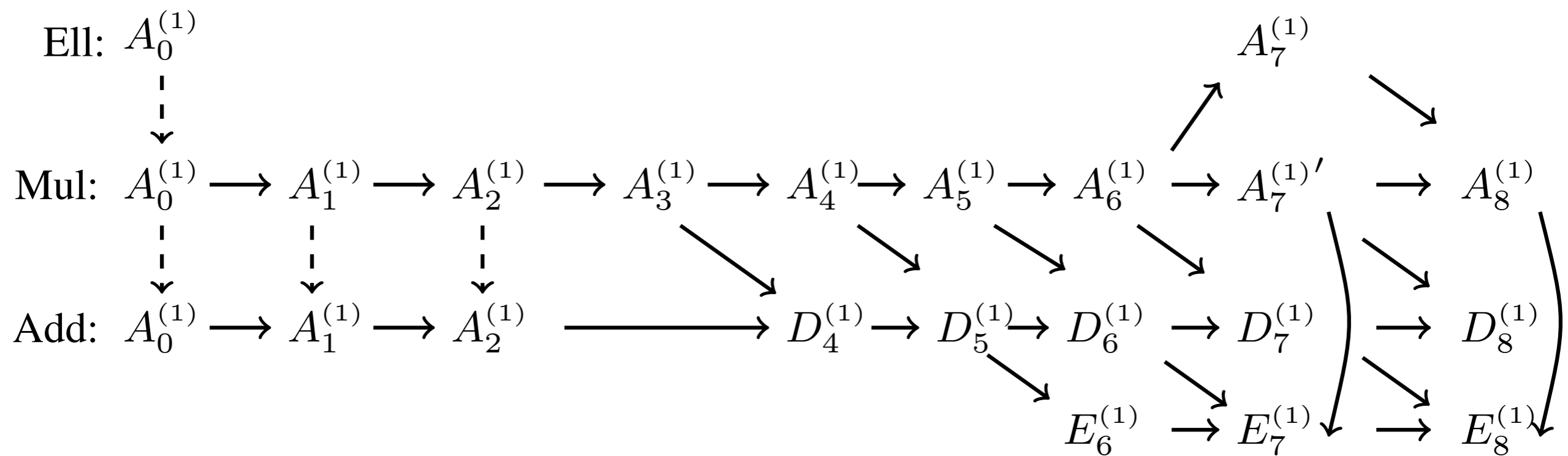

Initial-value spaces of all continuous and discrete Painlevé equations

Global results for P_I , P_{II} , P_{IV}

- The union of exceptional lines is a repeller for the flow.
- There exists a complex limit set, which is non-empty, connected and compact.
- Every solution of P_I , every solution of P_{II} whose limit set is not $\{0\}$, and every non-rational solution of P_{IV} intersects the last exceptional line(s) infinitely many times \Rightarrow infinite number of movable poles and movable zeroes.

Duistermaat & J (2011); Howes & J (2014); J & Radnovic (2014)

Inside P_1

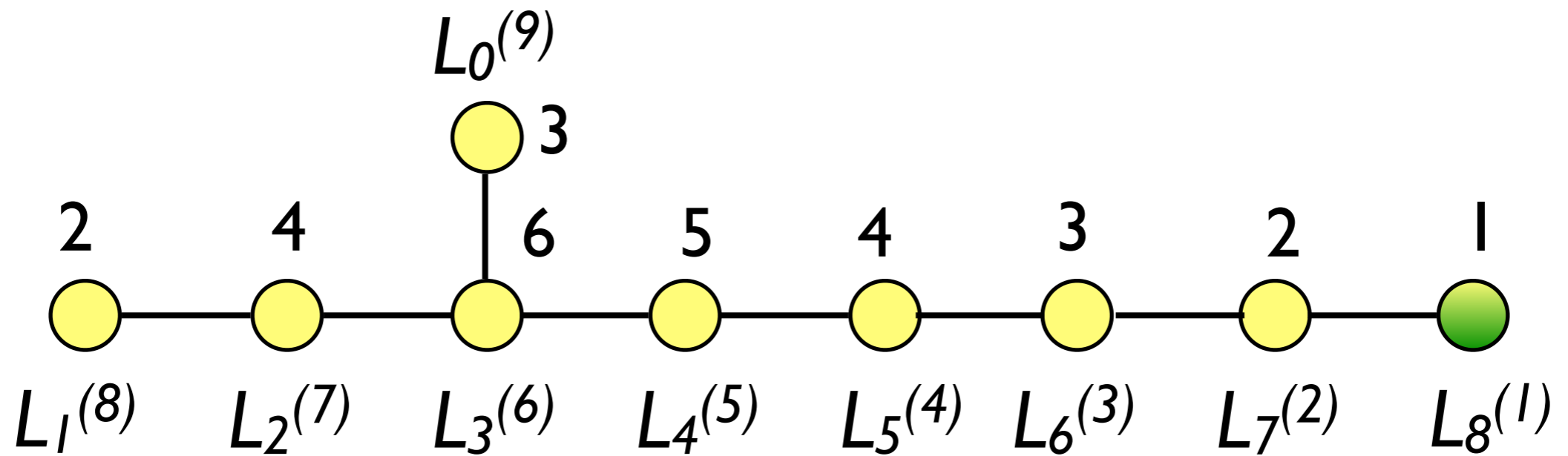

Affine extended E_8

At the heart

At the heart

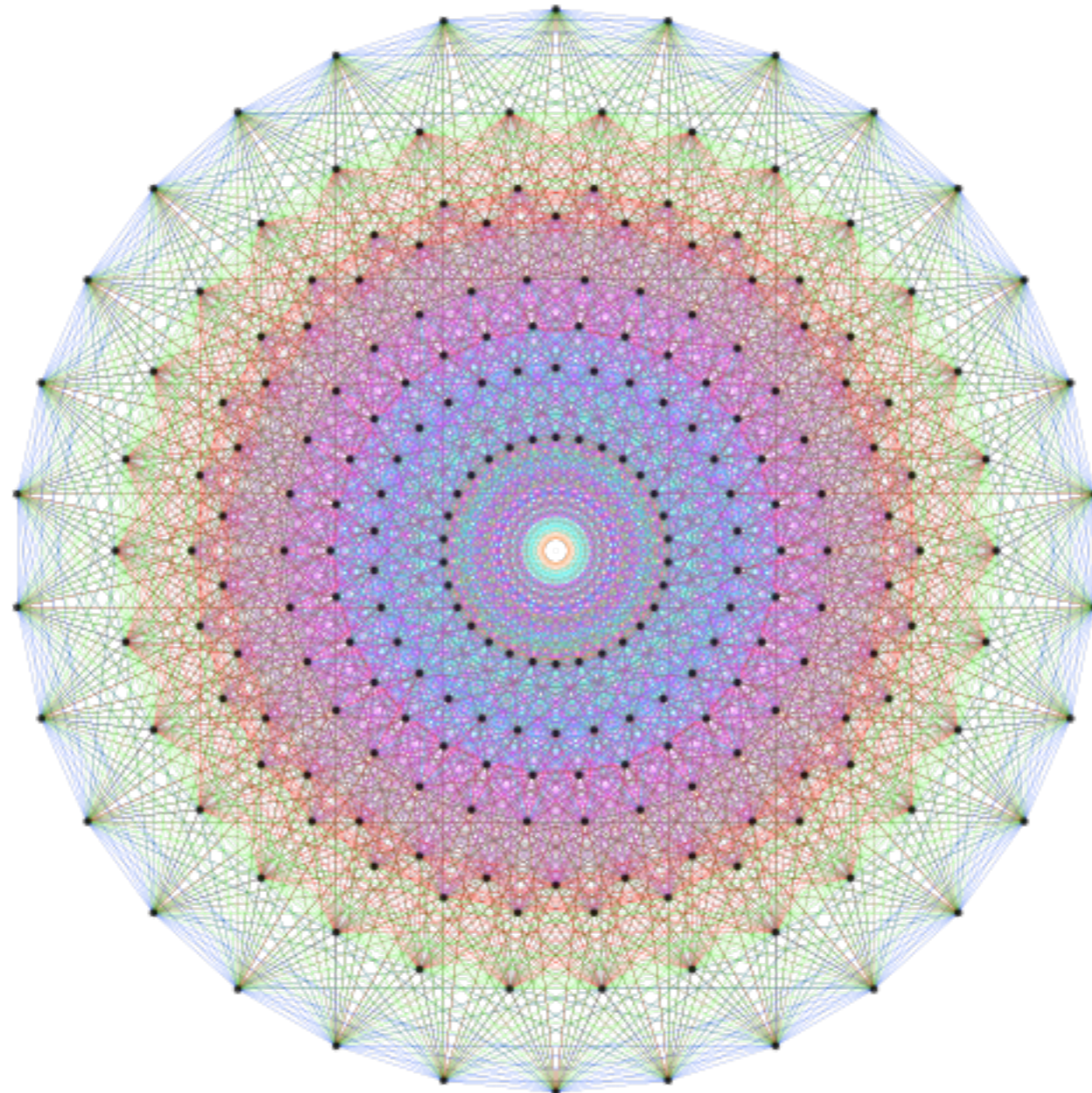

E_8

Symmetry groups

- Affine Weyl groups:
 - Natural lattice translations
 - Cremona isometries
 - \Leftrightarrow Painlevé equations



Sakai's Description II

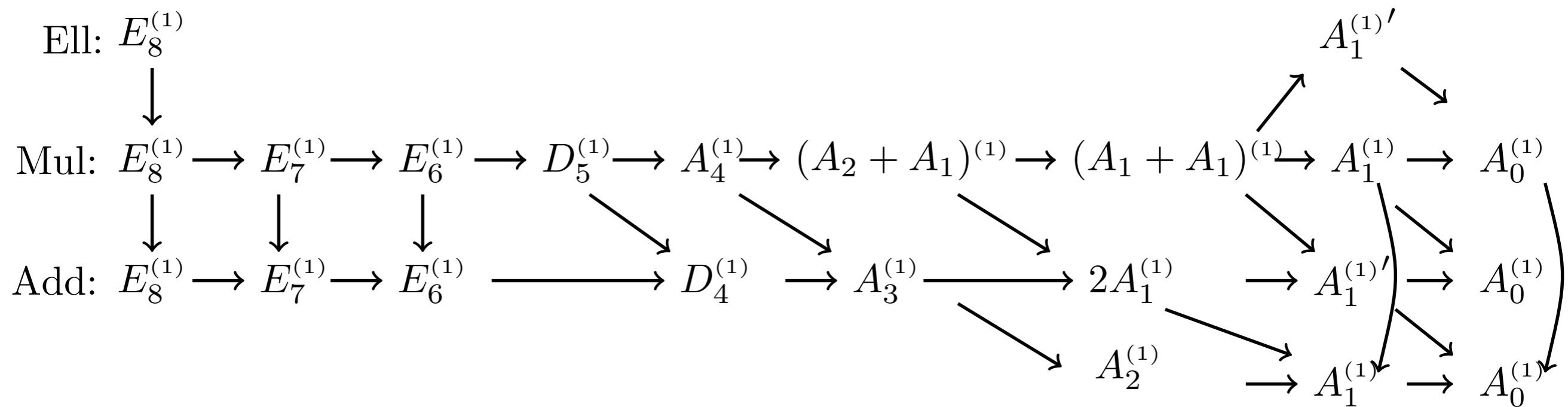

Symmetry groups of Painlevé equations

dP_1

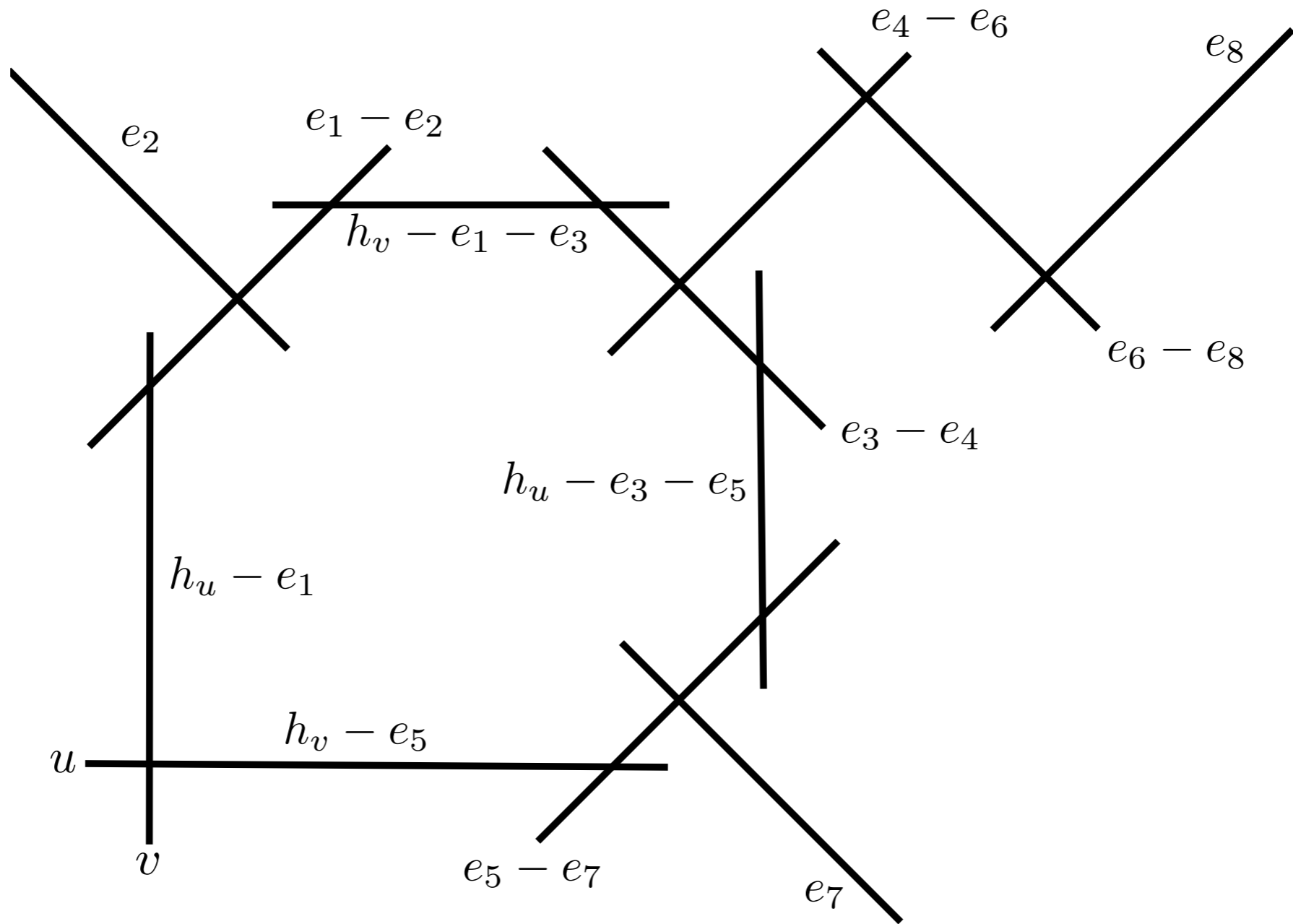

dP_1

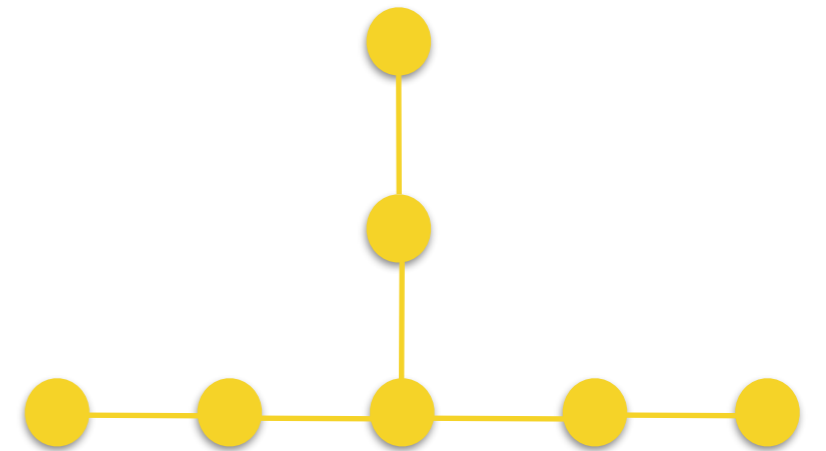
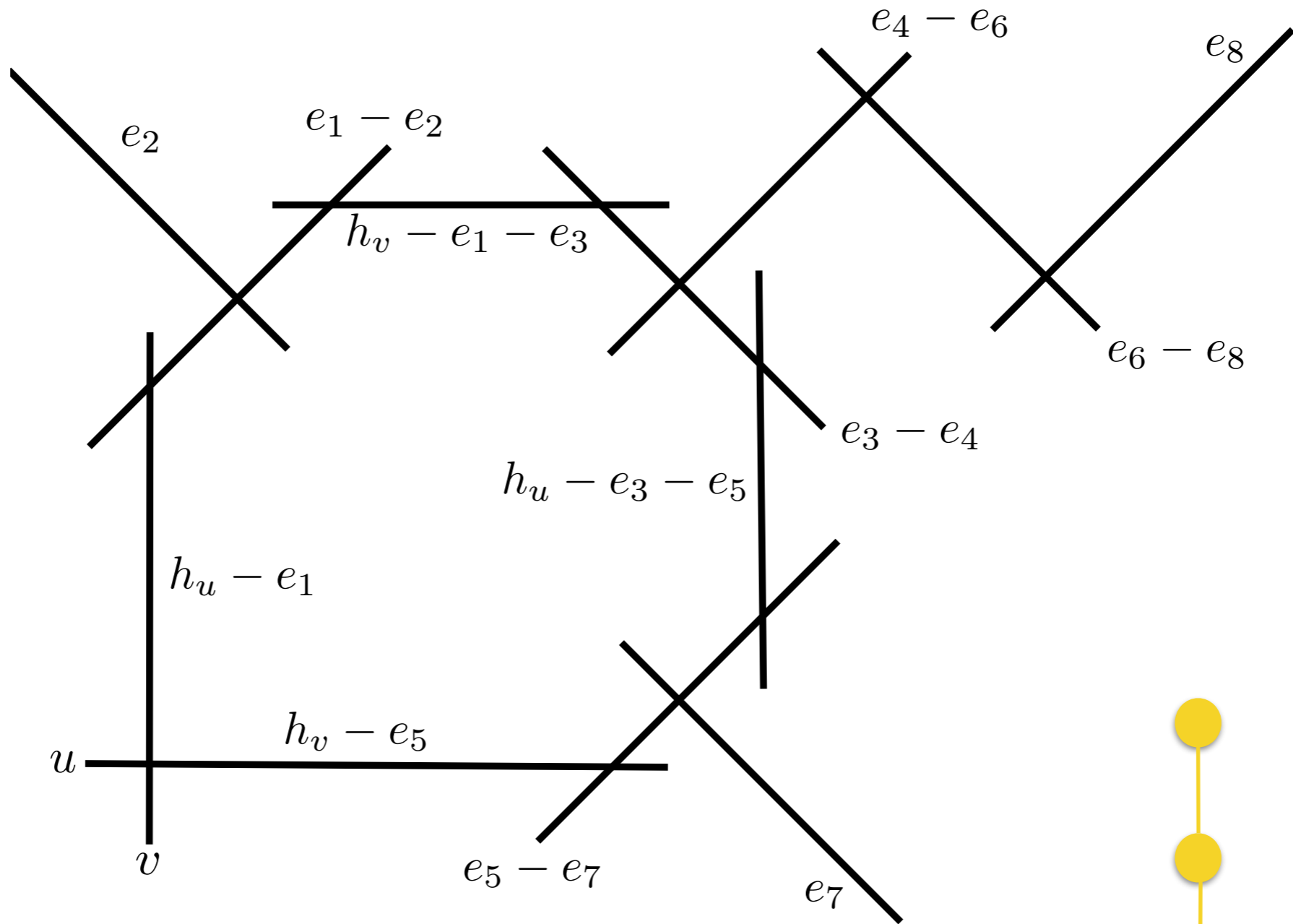

dP_1

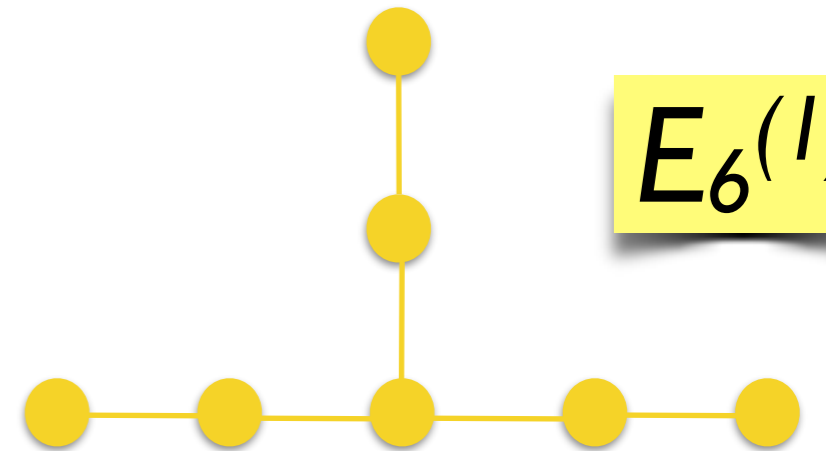
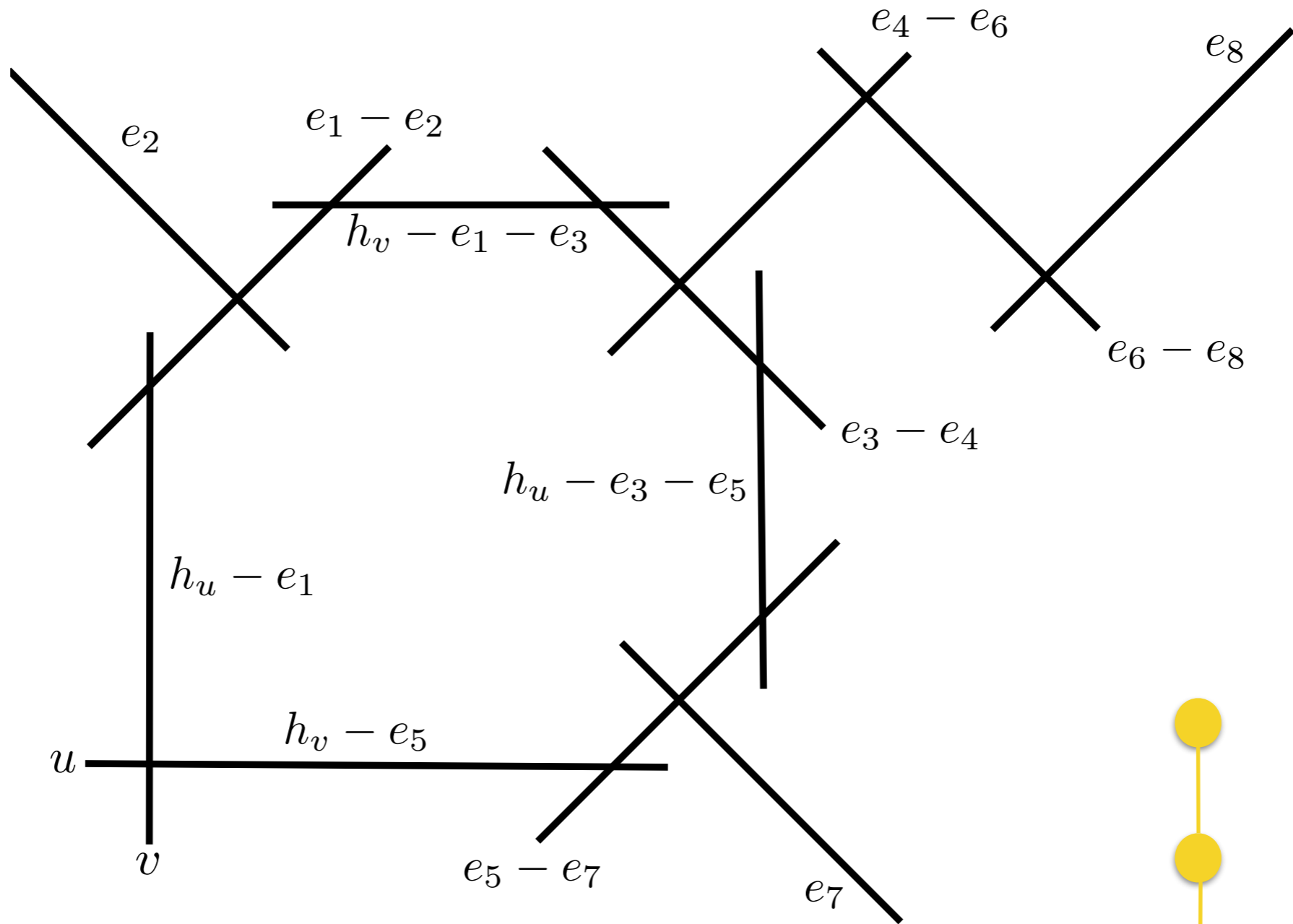

$E_6^{(1)}$

dP_1

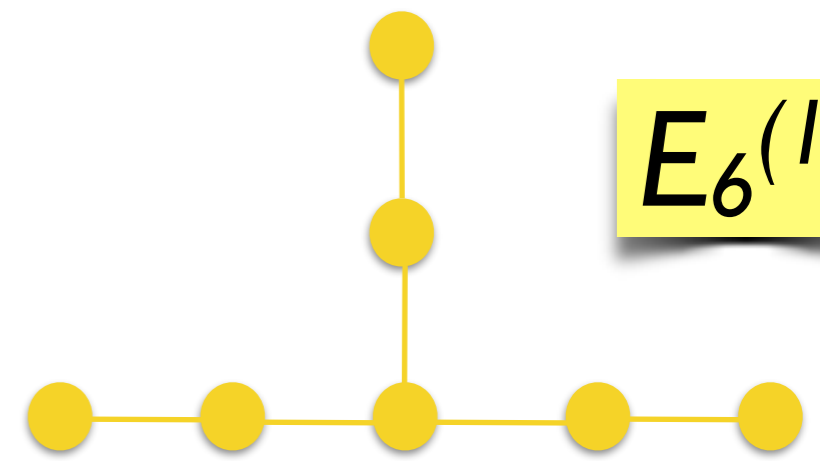
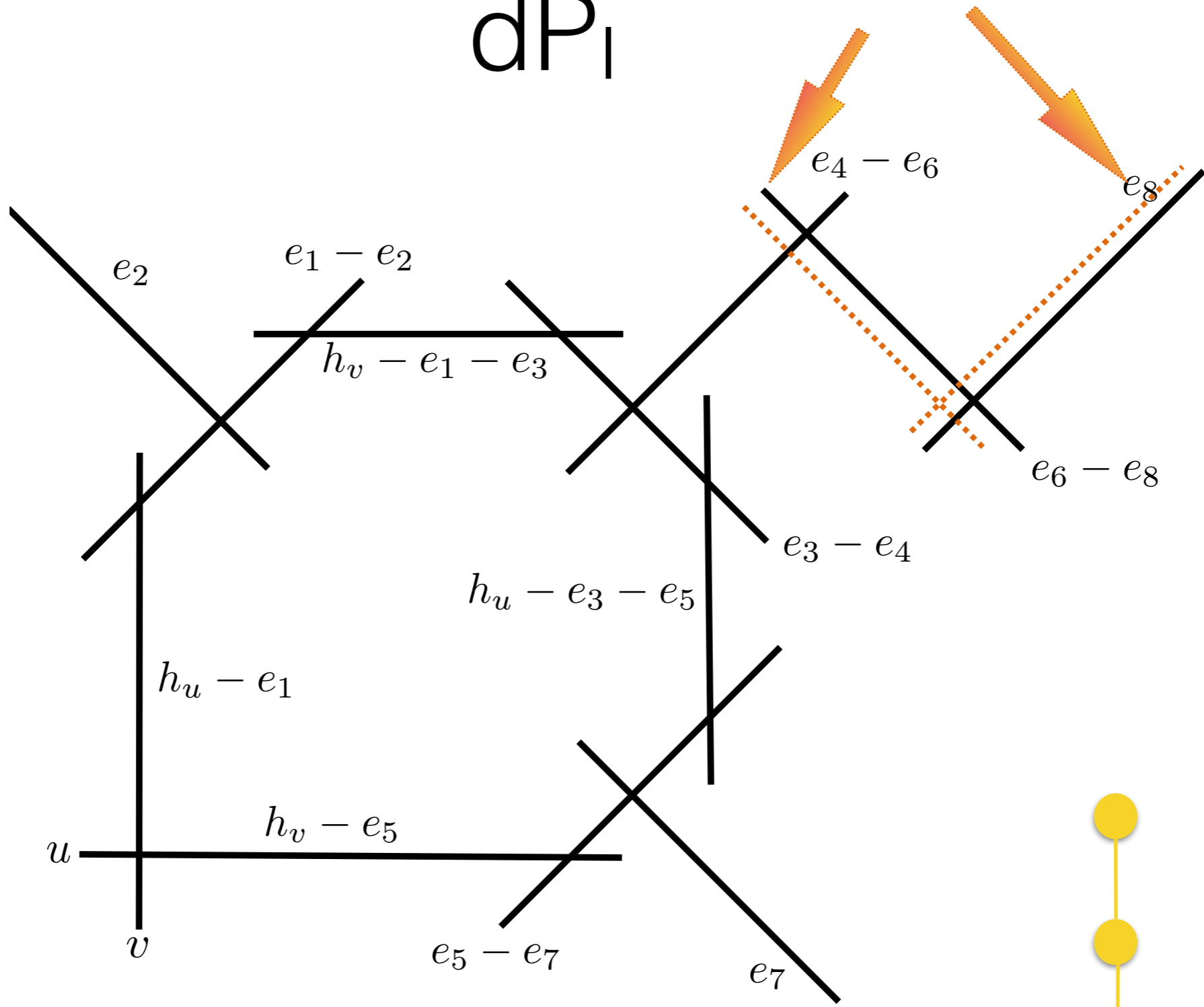

$E_6^{(1)}$

degenerate autonomous limit

dP_1

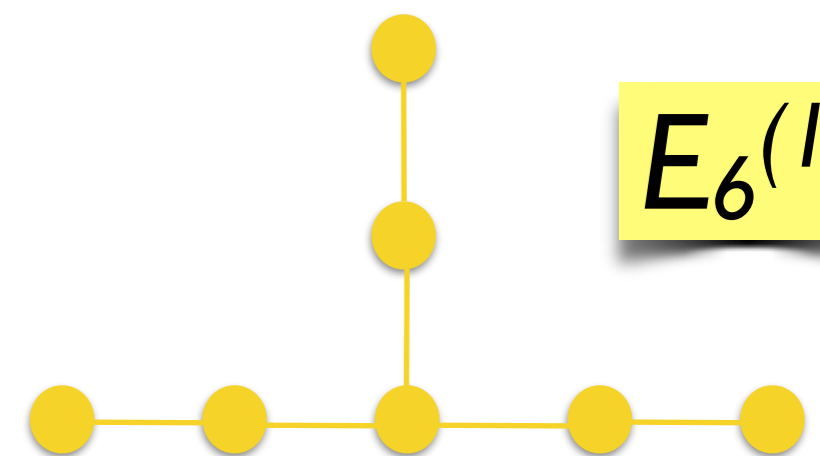
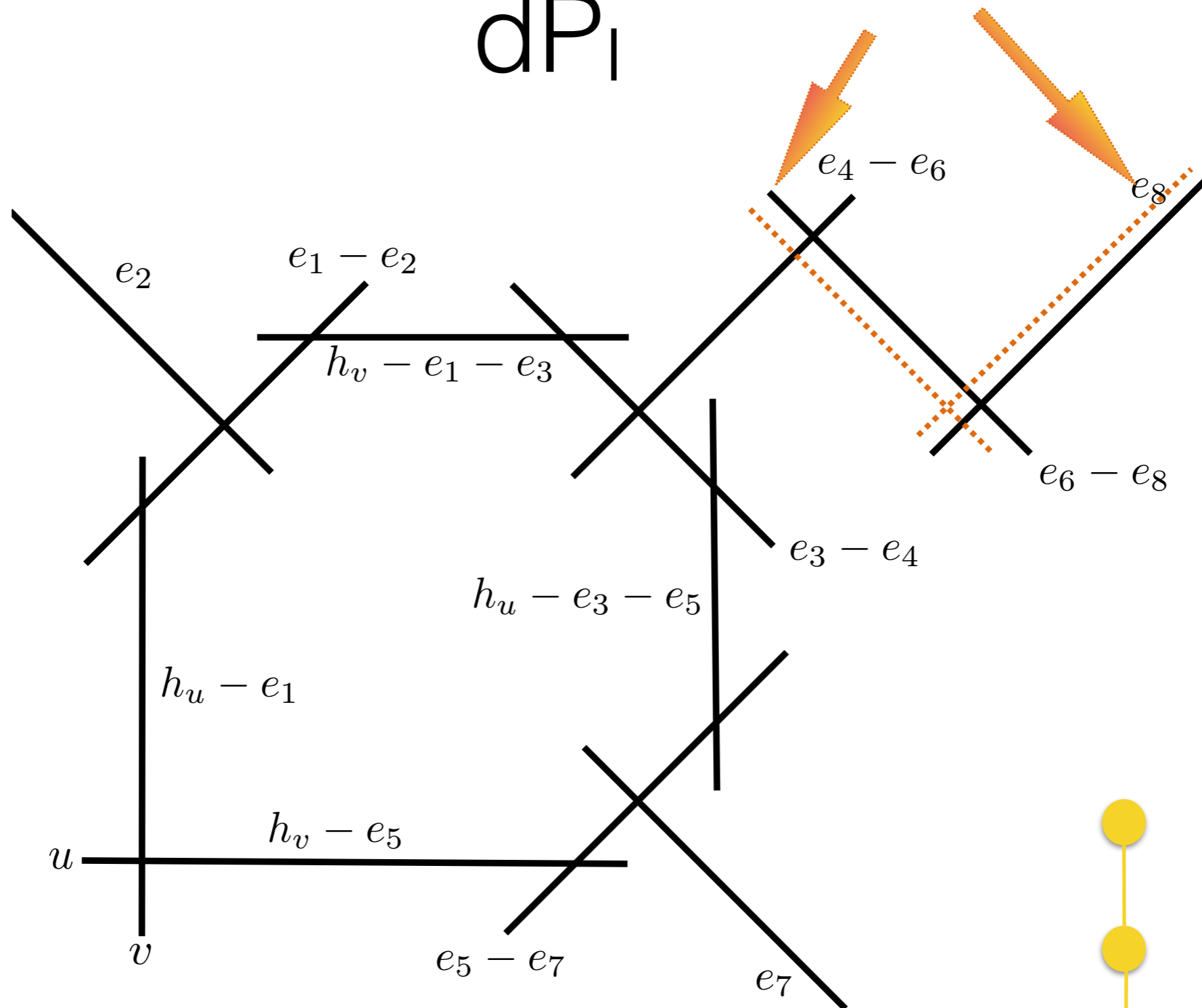

Solutions

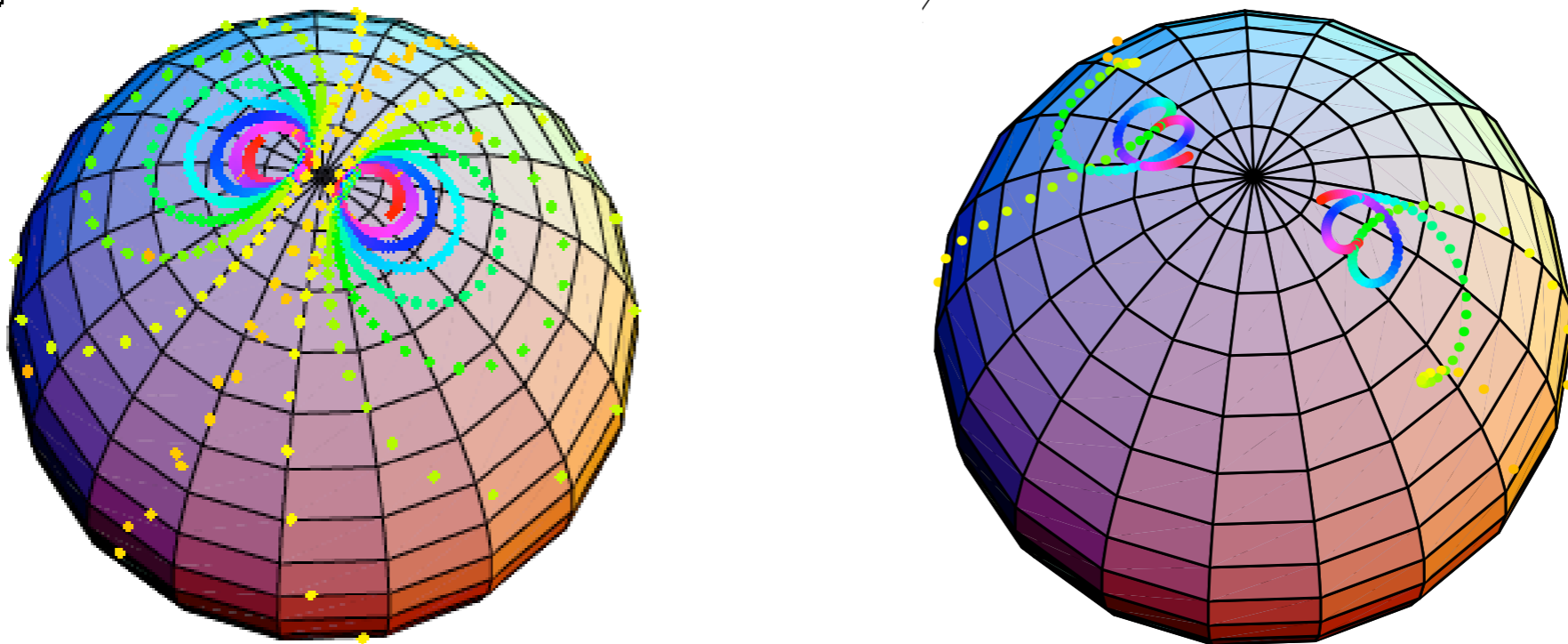

Solution orbits of scalar dP1 on the Riemann sphere (where the north pole is infinity).

Summary

- New mathematical models of physics pose new questions for applied mathematics
- **Global** dynamics of solutions of non-linear equations, whether they are differential or discrete, can be found through geometry.
- Geometry provides the only **analytic approach** available in \mathbb{C} for discrete equations.
- Tantalising questions about **finite properties** of solutions remain open.

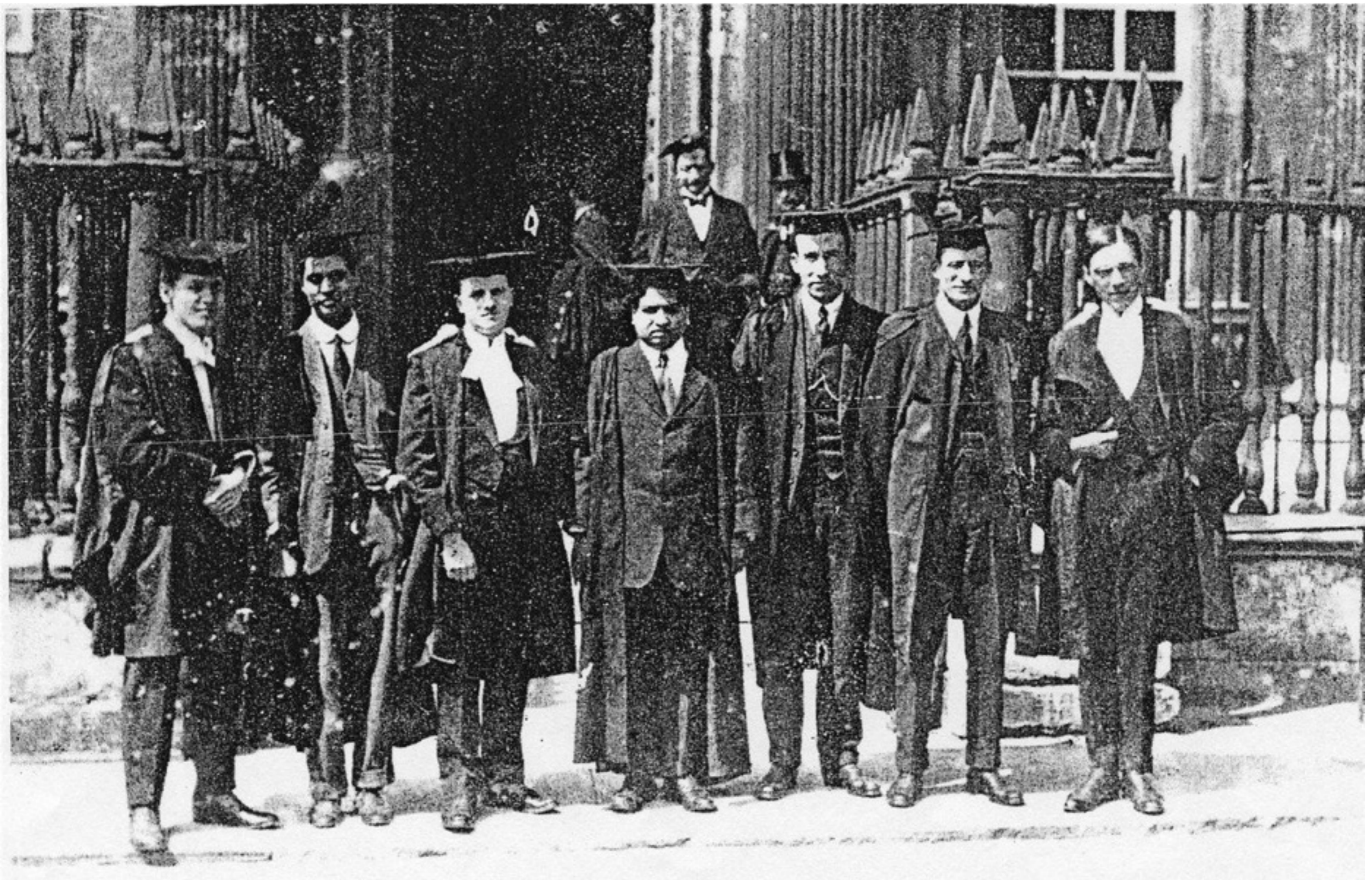

The mathematician's pattern's, like those of the painter's or the poet's, must be beautiful, the ideas, like the colours or the words, must fit together in a harmonious way. *GH Hardy, A Mathematician's Apology, 1940*